

# FURUNO

# OPERATOR'S MANUAL

MARINE RADAR

MODEL MODEL 1931 MARK-2



**FURUNO ELECTRIC CO., LTD.**  
NISHINOMIYA, JAPAN

©FURUNO ELECTRIC CO., LTD.

9-52, Ashihara-cho,  
Nishinomiya, Japan 662

Telephone: 0798-65-2111  
Telefax: 0798-65-4200 (G111)

All rights reserved. Printed in Japan

(TAYA)

PUB. No. OME-34340  
MODEL1931 MARK-2

Your Local Agent/Dealer

Initial : NOV 1995  
C : DEC. 9, 1996





# SAFETY INSTRUCTIONS

"**DANGER**", "**WARNING**" and "**CAUTION**" notices appear throughout this manual. It is the responsibility of the operator and installer of the equipment to read, understand and follow these notices. If you have any questions regarding these safety instructions, please contact a FURUNO agent or dealer.



## **DANGER**

This notice indicates a potentially hazardous situation which, if not avoided, will result in death or serious injury.



## **WARNING**

This notice indicates a potentially hazardous situation which, if not avoided, could result in death or serious injury.



## **CAUTION**

This notice indicates an unsafe practice which, if not avoided, could result in minor or moderate injury, or property damage.

# **WARNING**



**Hazardous voltage.**  
Can shock, burn, or cause death.

Only qualified personnel should work in the unit.

**Turn off the power at the ship's mains switchboard before beginning the installation. Post a warning sign near the switchboard to ensure the power will not be applied while the radar system is being installed.**

Electrical shock, fire, serious injury or death can result if the power is not turned off, or is applied while the equipment is being installed.

# **CAUTION**



**Ground both the display unit and the antenna unit.**

Ungrounded equipment can give off or receive interference or cause electrical shock.

**Confirm that the power supply voltage is compatible with the voltage rating of the equipment.**

Connection to the wrong power supply can cause fire or equipment damage. The voltage rating appears on the label at the rear of the display unit.

**Use only the supplied power cable.**

Use of other power cables (particularly a cables whose diameter is smaller than the supplied cable) can cause fire or short circuit.

**Use the correct fuse.**

Use of a wrong fuse can cause fire or equipment damage.

# NOTICE

**The installation must be done by a FURUNO representative or suitably qualified radar technician.**

Authorities require this.

**The mounting location must satisfy the following conditions:**

- Useable temperature: -15°C to 55°C
- Out of direct sunlight
- Away from air conditioner vents
- Well ventilated

**Observe the compass safe distances to prevent deviation of a magnetic compass.**

	Standard compass	Steering compass
Display Unit	0.8 m	0.6 m
Scanner Unit	1.1 m	0.8 m

**Keep magnets and magnetic fields away from the equipment.**

Magnetic fields will distort the picture and can cause equipment malfunction. Be sure the unit is well away from equipment which gives off magnetic fields (speaker, power transformer, etc.).

# TABLE OF CONTENTS

## **FOREWORD** **v**

---

Features ..... vi

## **SPECIFICATIONS** **vii**

---

## **OPERATIONAL OVERVIEW** **1-1**

---

The Control Panel .....	1-2
Turning the Radar On and Off .....	1-3
Turning on the radar .....	1-3
Turning off the radar .....	1-3
Transmitting & Stand-by .....	1-4
Transmitting .....	1-4
Stand-by .....	1-5
Basic Operation .....	1-6
Selecting a range .....	1-6
Adjusting receiver sensitivity .....	1-6
Adjusting the A/C SEA control (reducing sea clutter) ...	1-7
Selecting display mode .....	1-8
Adjusting display brilliance .....	1-9
Erasing the heading mark .....	1-9
About tuning .....	1-9
The Menu .....	1-10
Menu description .....	1-10
Menu operation .....	1-12
Measuring Range and Bearing .....	1-13
Range .....	1-13
Bearing .....	1-15
Using the Offset EBL .....	1-17
Predicting collision course .....	1-17
Measuring range and bearing between two targets .....	1-18
Reducing Interference .....	1-19
Types of interference .....	1-19
Rain clutter .....	1-19
Radar interference .....	1-20
Enlarging an Area of Interest (zoom) .....	1-21
Shifting the Picture (off center) .....	1-22
Guard Alarm .....	1-23
Selection of guard zone type .....	1-23
Setting a guard zone .....	1-24
Silencing the audible alarm .....	1-25
Canceling the guard zone and guard alarm .....	1-25

Notes on the guard alarm .....	1-25
Trailing Target Movement (echo trail) .....	1-26
Starting echo trailing .....	1-26
Adjusting brilliance of afterglow .....	1-27
Canceling echo trailing .....	1-27
Displaying Navigation Data .....	1-28
Magnifying Long Range Echoes (echo stretch) .....	1-29
Watchman .....	1-30
Turning on watchman .....	1-30
How watchman works .....	1-30
Canceling watchman .....	1-31
Summary of Display Indications .....	1-32

---

**APPLICATION** **2-1**

---

The Radar Wave and Radar Horizon .....	2-2
How the radar wave travels .....	2-2
Radar horizon .....	2-2
Target Properties and Radar Wave Reflection .....	2-3
Range Resolution .....	2-4
Bearing Resolution .....	2-5
False Echoes .....	2-6
Multiple echoes .....	2-6
Side-lobe echoes .....	2-7
Blind and shadow sectors .....	2-7
Indirect echoes .....	2-8
Position Fixing with Radar .....	2-9
By radar range .....	2-9
By range and bearing to a point on land .....	2-10
By two bearings .....	2-11
Nautical Chart and Radar Picture .....	2-12

---

**MAINTENANCE** **3-1**

---

Routine Maintenance, Location of Parts .....	3-2
Maintenance program .....	3-2
Replacing the fuse .....	3-3
Location of parts .....	3-3

---

**TROUBLESHOOTING** **4-1**

---

Troubleshooting Table .....	4-2
Location of Parts .....	4-5

**INSTALLATION****5-1**

Scanner Unit Installation .....	5-2
Siting, handling considerations .....	5-2
Mounting .....	5-3
Connections .....	5-4
Final preparation .....	5-5
Display Unit Installation .....	5-8
Mounting considerations .....	5-8
Mounting .....	5-9
Connections .....	5-10
Exchange of fuse for 24V/32V power supply .....	5-10
Connection of External Equipment .....	5-11
Heading sensor .....	5-11
Navigator .....	5-11
Checking the Installation .....	5-12
Adjustments .....	5-13
Entering antenna height, aligning heading, adjusting sweep timing .....	5-13
Magnetron heater voltage .....	5-17
Measuring blind and shadow sectors .....	5-18

**SCHEMATIC DIAGRAMS AND OUTLINE DRAWINGS**

Schematic Diagrams .....	S-1
Outline Drawings .....	D-1



*This page intentionally left blank.*

---

# FOREWORD

FURUNO Electric Company thanks you for purchasing the MODEL 1931 MARK-2 Marine Radar. We are confident you will discover why the FURUNO name has become synonymous with quality and reliability.

For over 40 years FURUNO Electric Company has enjoyed an enviable reputation for quality and reliability throughout the world. This dedication to excellence is furthered by our extensive global network of agents and dealers.

Your radar is designed and constructed to meet the rigorous demands of the marine environment. However, no machine can perform its intended function unless properly installed and maintained. Please carefully read and follow the installation, operation and maintenance procedures set forth in this manual.

We would appreciate feedback from you, the end-user, about whether we are achieving our purposes.

Thank you for considering and purchasing FURUNO.

■ **OPERATING CAUTION:** *No one navigational aid should be relied upon exclusively for the safety of vessel and crew. The navigator has the responsibility to check all aids available to confirm his position. Electronic aids are not a substitute for basic navigational principles and common sense.*

## Features

---

The MODEL 1931 MARK-2 has a large variety of functions, all contained in a rugged plastic case.

All controls respond immediately to the operator's command and each time a key is pressed, the corresponding change can be seen on the screen.

- Daylight viewing radar specially designed for small craft and sailing yachts.
- Traditional FURUNO reliability and quality in a compact, light-weight and low-cost radar.
- Precision 100 centimeter slotted waveguide antenna capable of 100 knot wind velocity.
- High definition 10" raster-scan display.
- Eight levels of target quantization for high target definition.
- On-screen alphanumeric readout of all operational information.
- Guard zone alarm watches for targets entering (or exiting) a guard zone.
- Operates on 12V, 24V or 32V DC power supply and consumes only 52 watts.
- The CRT can be turned off automatically during stand-by to reduce power consumption.
- Ship's position in latitude and longitude, ship's speed, and range and bearing to a waypoint can be shown in the bottom text area with navigation input in NMEA 0183 format.
- Two NMEA input ports.
- Outputting target position data (TLL) to navaid.

# SPECIFICATIONS

## SCANNER UNIT

<b>Radiator</b>	Slotted waveguide array
<b>Polarization</b>	Horizontal
<b>Antenna Rotation Speed</b>	24 rpm nominal
<b>Radiator Length</b>	100 cm
<b>Horizontal Beamwidth</b>	Less than 2.4°
<b>Vertical Beamwidth</b>	27°
<b>Sidelobe Attenuation</b>	Within ±20° of mainlobe: less than -24 dB Outside ±20° of mainlobe: less than -30 dB
<b>Wind Speed Resistance</b>	Relative wind speed 51.5 m/s (100 knots)

## TRANSCEIVER MODULE

<b>Frequency</b>	9410 MHz ±30 MHz (X band)
<b>Modulation</b>	P0N
<b>Peak Output Power</b>	4 kW nominal
<b>Transmitting Tube</b>	Magnetron MG5248 or E3571
<b>Warmup Time</b>	2 minutes 30 seconds

### Pulselength (PL) & Pulse Repetition Rate (PRR)

PL	PRR (Hz)	Range (nautical miles)															
		0.125	0.25	0.5	0.75	1	1.5	2	3	4	6	8	12	16	24	36	48
SP	2100	0.08 μs															
MP	1200							0.3 μs									
LP	600							0.8 μs									

SPECIFICATIONS

---

<b>Spurious Rejection</b>	Better than -40 dB
<b>Modulator</b>	FET Switching Method
<b>Intermediate Frequency</b>	60 MHz
<b>Tuning</b>	Automatic or manual
<b>Receiver Front End</b>	MIC (Microwave IC)
<b>Bandwidth</b>	Tx pulselength 0.08 $\mu$ s: 25 MHz Tx pulselength 0.3 $\mu$ s and 0.8 $\mu$ s: 5 MHz
<b>Duplexer</b>	Circulator with diode limiter

**DISPLAY UNIT**

<b>Indication System</b>	PPI Daylight display, raster scan
<b>Picture Tube</b>	10-inch rectangular (134 mm $\times$ 180 mm) monochrome CRT

<b>Range</b>	0.125	0.25	0.5	0.75	1	1.5	2	3	4	6	8	12	16	24	36	48
<b>Ring Interval</b>	0.0625	0.125	0.125	0.25	0.25	0.5	0.5	1	1	2	2	3	4	6	12	12
<b>No. of Rings</b>	2	2	4	3	4	3	4	3	4	3	4	4	4	4	3	4

<b>Range Resolution</b>	Better than 43 m
<b>Bearing Resolution</b>	Within 2.4°
<b>Minimum Range</b>	Better than 27 m
<b>Bearing Accuracy</b>	Within 1°
<b>Range Ring Accuracy</b>	0.9% of range or 8 m, whichever is the greater
<b>VRM Accuracy</b>	0.9% of range or 8 m, whichever is the greater
<b>Mark Indication</b>	Heading Mark, Bearing Scale, Range Rings, Variable Range Marker (VRM), Electronic Bearing Line (EBL), Tuning Bar, Cursor, Alarm Zone, Waypoint Mark (navigation input required), North Mark (heading sensor input required)

**Numerical/Character Indication** Range, Range Ring Interval, Pulselength (SP, MP, LP), Display Mode (HU, CU, NU, TM\*), Interference Rejection (IR1, IR2, IR3), Variable Range Marker (VRM), Electronic Bearing Line (EBL), Automatic A/C SEA (A/C AUTO), Stand-by (ST-BY), Radar Alarm (G (IN), G (OUT), G (ACKN)), Echo Stretch (ES1, ES2), Cursor position data (L/L or Range/Bearing), Echo Trailing (TRAIL), Trailing Time, Trailing Elapsed Time, Navigation Data (navigation input required), Heading (HDG, heading sensor input required)  
\* TM requires heading and speed data input.

**Interference Rejector** Built-in

## ENVIRONMENTAL CONDITIONS

**Vibration**

Vibration Freq	Total Amplitude
1 to 12.5 Hz	±3 mm
12.5 to 25 Hz	±0.75 mm
25 to 50 Hz	±0.2 mm

**Ambient Temperature** Scanner Unit: -25°C to +70°C  
Display Unit: -15°C to +55°C

**Humidity** Relative humidity, 95% or less at +40°C ±3°

## POWER SUPPLY & POWER CONSUMPTION

10.2 to 40V DC (52W; 28W in economy mode) or  
100V, 110V, 220V, 230V AC, 50/60 Hz, 1ø (rectifier required)

## COLOR

Unit	Color	
Scanner	Upper	N9.5
Display	Chassis	2.5GY5/1.5
	Panel	N3.0

## COMPASS SAFE DISTANCE

Unit	Standard Compass	Steering Compass
Display	0.8m	0.6m
Scanner	1.1m	0.8m

## EQUIPMENT LIST

## Complete Set

No.	Name	Type	Code No.	Qty	Remarks
1	Scanner Unit	XN8-RSB-0061-054	000-086-726	1	
2	Display Unit	RDP-104-1931M2-S	000-086-728	1	
3	Installation Materials (see below and select one, standard supply 10m)	CP03-16600	000-085-624	1 set	sig. cable assy. 10m
		CP03-16610	000-085-625		sig. cable assy. 15m
		CP03-16620	000-085-626		sig. cable assy. 20m
		CP03-16630	000-085-627		sig. cable assy. 30m
4	Accessories	FP03-04800	000-085-494	1 set	
5	Spare Parts	SP03-10100	000-085-680	1 set	

## Installation Materials

No.	Name	Type	Code No.	Qty	Remarks	
1	Signal Cable Assy.	S03-64-10	008-467-050	10m	Select one. Connector fitted at both ends.	
	Signal Cable Assy.	S03-64-15	008-467-060	15m		
	Signal Cable Assy.	S03-64-20	008-467-070	20m		
	Signal Cable Assy.	S03-64-30	008-467-080	30m		
2	Power Cable Assy.	CP03-12901	008-438-980	1		
3	Seal Washer	CW1053DX	000-850-021	4	For scanner unit, 9-13 supplied with radiator.	
4	Hex Bolt	M12 × 60 SUS304	000-862-191	4		
5	Hex Nut	M12 SUS304	000-863-112	4		
6	Flat Washer	M12 SUS304	000-864-132	4		
7	Spring Washer	M12 SUS304	000-864-263	4		
8	Slotted Pin G-type	ø10 × 45 SUS304	000-866-390	2		
9	Hex Bolt	M8 × 30 SUS304	000-862-187	4		
10	Flat Washer	M8 SUS304	000-864-130	4		
11	Spring Washer	M8 SUS304	000-864-262	4		
12	O-ring	JISB2401-1A-G80	000-851-313	1		
13	Three Bond	#1211 (50g)	000-854-118	1		
14	Packing for Sig. Cable RW-6537	03-121-3002-0	100-191-070	1		tapped inside scanner unit (optional use)
15	EH Connector Assy.	EH4P-L100	000-137-592	1		

**Accessories**

No.	Name	Type	Code No.	Qty	Remarks
1	Hood Assy.	FP03-04810	008-441-400	1	
2	Hanger	FP03-04820	008-441-410	1	Incl. five M6 × 20 tapping screws

**Spare Parts**

No.	Name	Type	Code No.	Qty	Remarks
1	Fuse	FGBO 10A 125VAC	000-549-065	2	For 12V DC power supply
2	Fuse	FGBO-A 5A 125VAC	000-549-064	2	For 24V/32V DC power supply

**Optional Equipment**

No.	Name	Type	Code No.	Remarks
1	Rectifier	RU-3423	000-030-443	For AC power supply
2	External Buzzer	OP03-21	000-030-097	
3	NMEA Cable	MJ-A6SPF0011-050	000-132-244	For E/S
		MJ-A6SPF0011-100	000-132-336	
		MJ-A6SPF0012-050	000-134-424	For Navaid
		MJ-A6SPF0012-100	000-133-817	
4	Gyro Cable Assembly	MJ-A6SPF0009-100	000-125-236	For connection of gyro interface, 10m
5	Magnifying Lens	03-121-1500	008-439-000	For display unit
6	Flush Mount Kit M1831	OP03-91	008-445-060	



*This page intentionally left blank.*



## The Control Panel

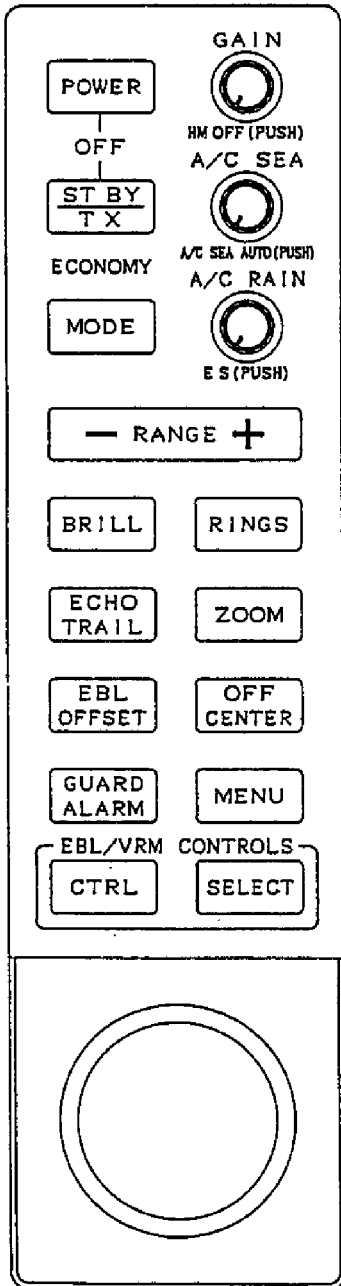

Figure 1-1 Controls

### POWER

Turn on power. Press together with **STBY TX** to turn off power.

### STBY TX

Alternate between stand-by and transmit.

### ECONOMY

Lights when the economy mode is on.

### MODE

Select display mode.

### RANGE

Select range.

### BRILL

Adjust display brilliance.

### ECHO TRAIL

Show target movement in afterglow.

### EBL OFFSET

Measure range and bearing between two targets, predict collision course.

### GUARD ALARM

Set or cancel guard alarm zone, silence audible alarm.

### CTRL

Enable control of VRM or EBL by trackball.

### GAIN

#### HM OFF (PUSH)

Control: Adjust sensitivity of radar receiver.

Switch\*: Temporarily erase heading mark (and north mark and menu if displayed).

#### A/C SEA

#### A/C SEA AUTO (PUSH)

Control: Reduce sea clutter. Switch: Turn auto sea clutter adjustment on or off.

#### A/C RAIN

#### ES (PUSH)

Control: Reduce rain clutter. Switch: Enlarge echoes.

#### RINGS

Turn range rings on or off and adjust their brilliance.

#### ZOOM

Double size of area between your vessel and location selected by cursor.

#### OFF CENTER

Shift your vessel's position to cursor location.

#### MENU

Display or erase menu.

#### SELECT

Select EBL or VRM.

#### Trackball

- shift cursor, EBL and VRM
- set guard alarm zone
- select menu, sub menu, option
- shift origin of EBL and VRM

\*: Pressing the switch alternates the cursor position data display mode and outputs the target position data (TLL) to the navaid.

## Turning the Radar On and Off

- **CAUTION:** *The radar scanner emits high frequency radio radiation which can be harmful, particularly to your eyes. Never look directly into the scanner from a distance of less than two feet when the radar is in operation as you could injure the cornea of your eyes. Always make sure no person is near the scanner unit before turning on the radar.*

### Turning on the radar

Press the **POWER** key.

#### When you turn on the radar;

- The control panel lights.
- A timer displays the time remaining for warm up of the magnetron, counting down from 2:29 to 0:01. (The magnetron is the pulsed microwave radiation source for radar. It takes about two minutes and thirty seconds to warm up before the radar can be operated.)

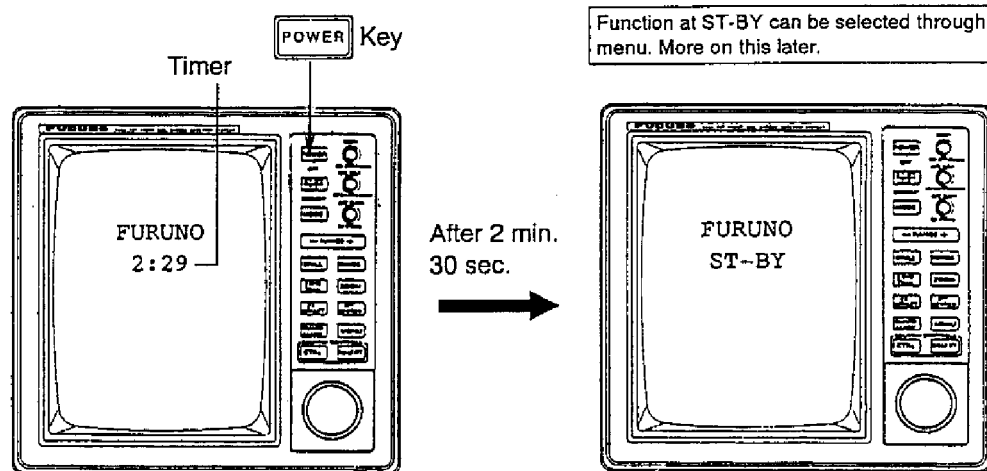

Figure 1-2 Display unit, showing location of timer

### Turning off the radar

Press **POWER** and **STBY TX** keys together.

## Transmitting & Stand-by

### Transmitting

After the power is turned on and the magnetron has warmed up, "ST-BY" (Stand-By) appears at the screen center. In stand-by the radar is available for use at anytime—but no radar waves are being transmitted.

Press the **STBY TX** key to transmit. When the radar is transmitting, any echoes from targets appear on the display. This radar displays echoes in eight levels according to echo strength.

Each time the radar is powered (except initial power on) it begins operation with last used settings for echo stretch, menu, display mode, tuning method (automatic or manual), range, display brilliance, echo trail, picture off center, EBL/VRM, A/C SEA (automatic or manual) and guard alarm.

#### Indications and marks shown on the display

Table 1-1 describes the indications and marks which are always shown on the display.

*Table 1-1 Display indications and marks*

Indication/Mark	Location	Function
Range	Top left-hand corner	
Range Ring Interval	Below "Range"	
Pulselength	Below "Ring Interval"	
Heading Mark	Solid radial line at 0 degrees. Always displayed.	Show your vessel's heading.
Cursor	The cursor is a "+" mark and always displayed.	Measure range and bearing to target, set guard zone.
Range and Bearing to Cursor Intersection	Bottom of display	
Sweep	Rotating radially around the display.	Tell the operator the radar is functioning properly. The sweep rotates synchronously with the scanner, so at any given time the direction in which the scanner is pointing is known. With every rotation echoes appear on the sweep as brighter spots of light, thus presenting a complete picture of the surrounding area.
Bearing Scale	Outermost ring (marked in degrees)	Measure bearing.

## Stand-by

When you won't be using the radar for an extended period, but you want to keep it in a state of readiness, place it in stand-by by pressing the **STBY TX** key. The display shows "ST-BY" or navigation data, or goes into the economy mode depending on menu setting. (More on menu operation later.)

### Economy mode

The CRT can be set to automatically turn itself off (through the "Mode & Function" menu) when in stand-by to reduce power consumption. This feature is called the "economy mode." Power consumption in the economy mode is 28W.

### Navigation data display during stand-by

If a navigation aid inputs navigation data to this radar, navigation data can be displayed during stand-by. You can turn the navigation data display on (or off) through the "Nav Data" menu. Figure 1-3 shows a typical navigation data display during stand-by.

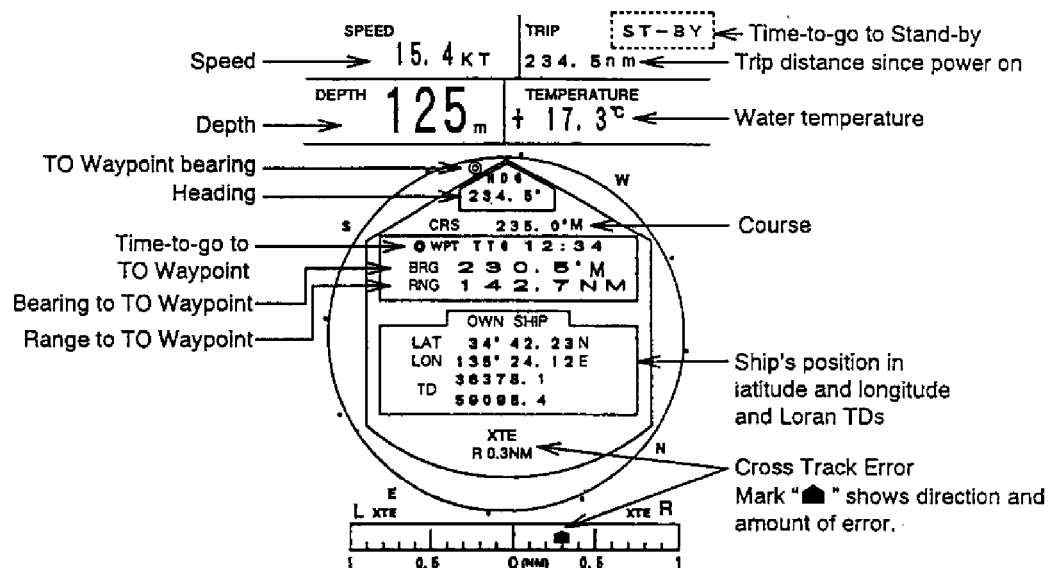

Figure 1-3 Typical navigation data display during stand-by

- **NOTE 1:** Availability of a particular display item depends on incoming data.
- **NOTE 2:** When Range to Waypoint reaches 0.1nm, the WPT mark jumps to dead ahead even though a difference may exist between heading and BRG to WPT.
- **NOTE 3:** When cross track error exceeds 1nm on either side, the XTE mark starts blinking.

## Basic Operation

---

### Selecting a range

The range selected automatically determines the range ring interval, the number of range rings and pulse repetition rate, for optimal detection capability in short to long ranges. You can select which ranges and pulselength (for 1.5 and 3 mile ranges) to use through the “Mode & Function” menu. The range, range ring interval and pulselength appear at the top left-hand corner of the display.

#### To select a range;

Press the **RANGE** key. Each time the range is changed the newly selected range appears momentarily at the top left-hand side of the display for your confirmation.

#### Tips for selecting range

- When navigating in or around crowded harbors, select a short range to watch for possible collision situations.
- If you select a lower range while on open water, increase the range occasionally to watch for vessels that may be heading your way.

### Adjusting receiver sensitivity

The **GAIN** control adjusts the sensitivity of the receiver. It works in precisely the same manner as the volume control of a broadcast receiver, amplifying the signals received.

#### How to adjust the sensitivity

The proper setting is such that the background noise is just visible on the screen. Adjust the sensitivity on the highest range; the background noise is clearer on that range. If you set up for too little sensitivity, weak echoes may be missed. On the other hand excessive sensitivity yields too much background noise; strong targets may be missed because of the poor contrast between desired echoes and the background noise on the display.

- 1) Transmit on long range.
- 2) Adjust the **GAIN** control so background noise is just visible on the screen.

## Adjusting the A/C SEA control (reducing sea clutter)

Echoes from waves can be troublesome, covering the central part of the display with random signals known as "sea clutter." The higher the waves, and the higher the scanner above the water, the further the clutter will extend. Sea clutter appears on the display as many small echoes which might affect radar performance. (See the left-hand figure in Figure 1-4.). When sea clutter masks the picture, adjust the **A/C SEA** control, either automatically or manually, to reduce the clutter.

### How the A/C SEA control works

The **A/C SEA** control reduces the amplification of echoes at short ranges (where clutter is the greatest) and progressively increases amplification as the range increases, so amplification will be normal at those ranges where there is no sea clutter.

### Manually adjusting the A/C SEA control

The proper setting of the A/C SEA should be such that the clutter is broken up into small dots, and small targets become distinguishable.

If the control is set too low, targets will be hidden in the clutter, while if it is set too high, both sea clutter and targets will disappear from the display. In most cases adjust the control until clutter has disappeared to leeward, but a little is still visible windward.

- 1) Confirm that the sensitivity is properly adjusted, and then transmit on short range.
- 2) Adjust the **A/C SEA** control so small targets are distinguishable but some clutter remains on the display.

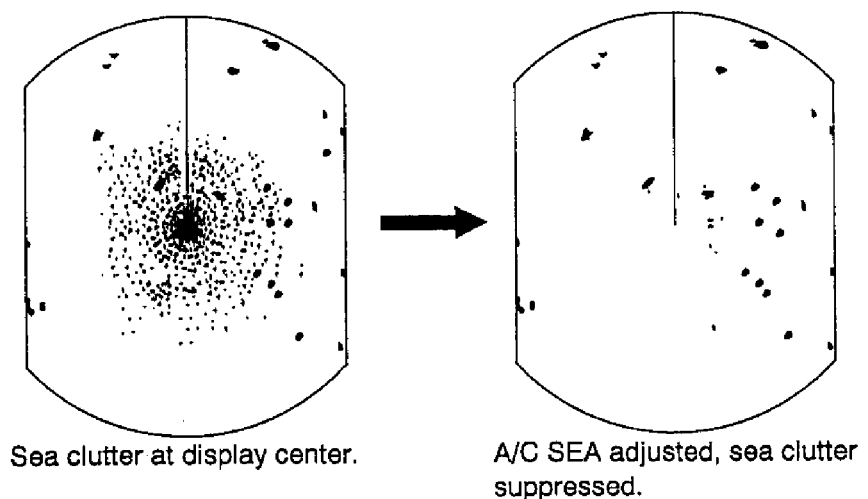

*Figure 1-4 How to adjust the A/C SEA control*



### Tip for adjusting the A/C SEA

A common mistake is to over-adjust the circuit so all the clutter is removed. As an example set up for maximum A/C SEA. You will see how the center of the display becomes dark. This dark zone can be dangerous (targets may be missed), especially if the sensitivity is not properly adjusted. Always leave a little clutter visible on the display to be sure weak echoes will not be suppressed. If there is no clutter visible on the display, turn off the circuit.

### Automatic adjustment of A/C SEA

Push the **A/C SEA** control. "A/C AUTO" appears at the bottom left-hand corner of the display. You can fine tune by adjusting the control.

## Selecting display mode

Three display modes are available: heading up, north up, course up, and true motion. (North up and course up require heading sensor input and True motion requires heading sensor and speed log input.) Press the **MODE** key to select mode. Each time the key is pressed, if a heading sensor is connected to the radar, the display and the display mode indication at the top left-hand corner of the display change in the sequence of HU (heading up), CU (course up), NU (north up) and TM (true motion). If there is no heading sensor connection, the display mode is always HU and the **MODE** key is inoperative; it emits several beeps when pressed.

■ **NOTE:** *The radar begins operation with last selected display mode (except course up) whenever the unit is turned on.*

### Heading up

The picture is oriented so the heading mark is at the top of the display. This mode is useful for navigation in congested waters.

### Course up

The course up mode shows ship's heading, by the heading mark, at the top of the display. To get heading desired, steer vessel in direction desired, and then press the **MODE** key to show "CU" at the top left-hand corner of the display.

### North up

North is at the top of the display and the heading mark moves with ship's heading. This mode is useful for determining ship's position and as a navigation monitor on a nautical chart. The

picture is stabilized against yaw of vessel, thereby reducing smearing of target echoes.

### True motion

True motion displays own ship and moving objects in their true motion.

### **Adjusting display brilliance**

The **BRILL** key adjusts the brilliance of the display in sixteen levels including off. Each time the key is pressed the newly selected brilliance appears momentarily at the top of the display for your confirmation.

### **Erasing the heading mark**

The heading mark continuously appears on the display and shows your vessel's heading. When this mark obscures a target echo, you can temporarily erase it, as well as the north mark and the menu (if displayed), by pressing and holding down the **GAIN** control. Release the control to re-display those marks and the menu.

### **About tuning**

The radar receiver can be tuned automatically or manually. The tuning bar at the top right-hand corner of the display shows tuning condition. Generally, the longer the tuning bar the better the tuning condition, however the length of the bar changes with number of radar echoes, range and other factors. Tuning method is also shown above the tuning bar as "AUTO" or "MANUAL."

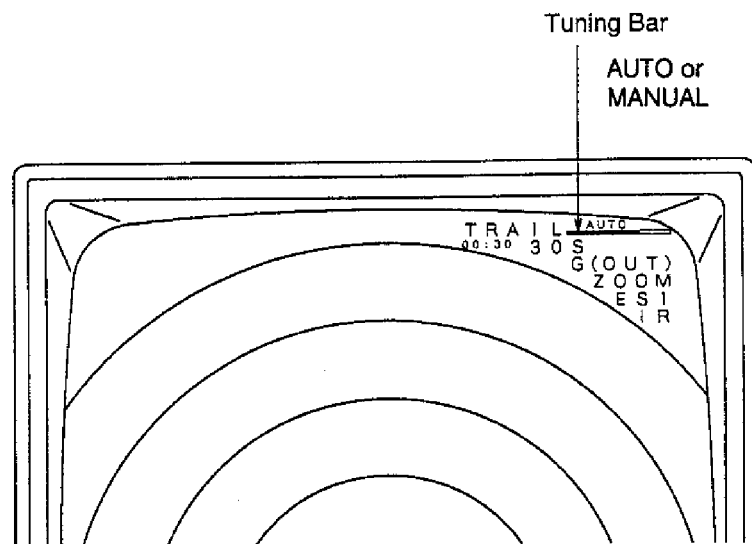

*Figure 1-5 Tuning bar*

For how to tune the radar manually see Table 1-2 on page 1-11.

## The Menu

The main menu, consisting of seven menus, contains less-often used functions which once preset do not require regular adjustment. To display or close the menu, press the **MENU** key. You can select menus, sub menus and options by the trackball. Note that the menu can also be displayed (and options selected) while the radar is in stand-by.

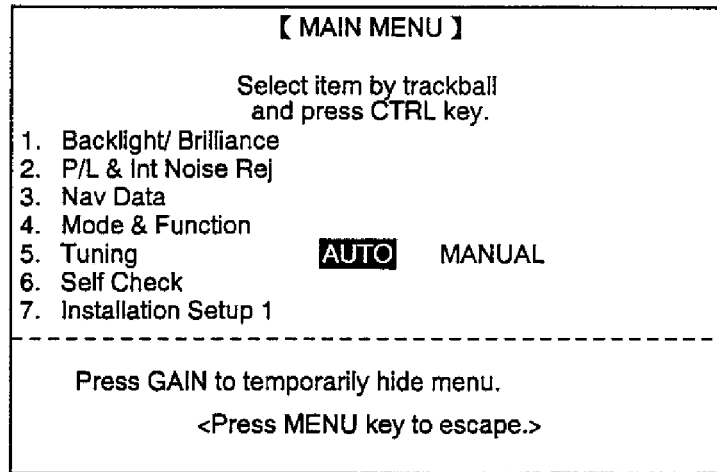

Figure 1-6 Main menu

**Menu description** Table 1-2 describes the main menu.

*Table 1-2 Main menu description*

Menu	Sub Menu	Function
1. Backlight/Brilliance	1. Panel	Select level of panel backlight.
	2. Heading Mark	Select brilliance of heading mark.
	3. Other Marks	Select brilliance of VRM, EBL, cursor, guard zone and WP.
	4. Characters	Select brilliance of characters.
	5. Echo Trails	Select brilliance of echo trails.
2. P/L & Int/Noise Rej	1. Pulselength	Select pulselength for 1.5 and 3 mile ranges.
	2. Int Reject	Select level of interference rejection.
	3. Noise Reject	Select "ON" to reject noise.
3. Nav Data	1. Navigator	Select source of navigation data.
	2. Nav Data Disp	Turn navigation data display on or off.
	3. Pos Disp Mode	Display position in lat/long or loran TD.

(Continued)

Menu	Sub Menu	Function
3. Nav Data	4. Depth Unit	Select depth unit for meter, fathom or feet.
	5. Temp. Unit	Select water temperature unit for °C or °F.
4. Mode & Function	1. STBY Display	Select "Display" on stand-by; display "ST-BY" or navigation data, or go into the economy mode.
	2. Watchman	Turn watchman on (set rest period) or off.
	3. Alarm Mode	Select condition which triggers guard alarm; in (target enters guard zone) or out (target exits guard zone).
	4. VRM Unit	Select distance unit of VRM and cursor for nm, km or sm.
	5. EBL Ref	Select EBL reference for relative or true.
	6. Range	Select useable ranges.
5. Tuning	AUTO, MANUAL	Select automatic or manual tuning. To tune manually; <ul style="list-style-type: none"> <li>1. Select MANUAL by trackball.</li> <li>2. Press the <b>CTRL</b> key to enable manual tuning.</li> <li>3. While pressing and holding down the <b>GAIN</b> control, operate the trackball.</li> <li>4. Press the <b>CTRL</b> key.</li> </ul> <p>"MANUAL" appears at the top right-hand corner when manual tuning is in effect.</p>
6. Self Check		Test controls, ROM and RAM, check antenna rotation speed, and display program no.
7. Installation Setup 1 (for service technicians)  To access the installation menus, first turn off the power. Then, while pressing and holding down the <b>GAIN</b> control (at least three seconds) press the <b>POWER</b> key.	1. Key Beep	Turn key beep on or off.
	2. Alm Sense Lvl	Select minimum echo strength which triggers guard alarm.
	3. Hdg Sensor	Select heading sensor; magnetic compass or gyrocompass.
	4. Ant on Tx	Select antenna status on transmission; rotate or stop.
	5. Ant Height	Enter antenna height to optimize STC.
	6. Operation Mode	Select operation mode; master or slave.
	7. Installation Setup 2	<ul style="list-style-type: none"> <li>1) Align heading by EBL1.</li> <li>2) Adjust sweep timing by trackball.</li> <li>3) Set on hours by trackball.</li> <li>4) Set Tx hours by trackball.</li> </ul>

**Menu operation**

- 1) Press the **MENU** key to display the main menu.
- 2) Operate the trackball to select a menu; for example, the Backlight/Brilliance menu. As you move the highlighted cursor down through the menu, each menu number, initially shown in white on green, inverses to green on white. This shows the associated menu is available for selection. Also, menu selection guidance appears at the bottom of the menu window.
- 3) Press the **CTRL** key. Figure 1-7 shows the Backlight/Brilliance menu.

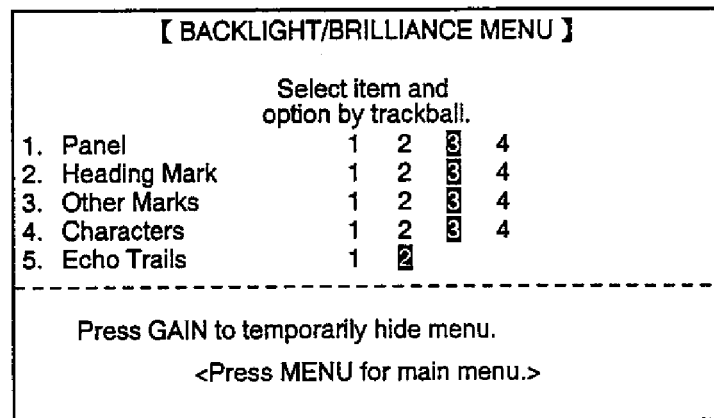

*Figure 1-7 Backlight/brilliance menu*

- 4) Operate the trackball to select sub menu.
- 5) Operate the trackball to select option. Current settings are shown in inverse video.
- 6) Press the **MENU** key twice to close the menu.

## Measuring Range and Bearing

In the basic radar system your ship is in the center of the display, and any target received appears in a map-like projection throughout 360 degrees. This allows the bearing and range from your vessel to a target appearing on the display to be measured.

### Range

You can measure the range to a target three ways:

- by the range rings
- by the cursor, and
- by the VRM (Variable Range Marker).

#### Range rings

To get a rough measurement of the range to a target, use the range rings. Press the **RINGS** key to turn on the range rings. Further pressing of the key adjusts their brilliance or turns them off. Each time the key is pressed the newly selected brilliance level appears momentarily at the top of the display for your confirmation.

To measure range by the range rings, count the number of rings between the center of the display and the target. Check the range ring interval and judge the distance of the echo from the inner edge of the nearest ring.

#### Cursor

To measure range by the cursor, rotate the trackball to place the cursor intersection on the inside edge of the target. The range to the cursor intersection appears at the bottom of the display.

#### VRM

- 1) Press the **SELECT** key to circumscribe a VRM readout (at the bottom right-hand corner). Each press of the key selects the readout of VRM1, VRM2, EBL1 or EBL2 in that order.

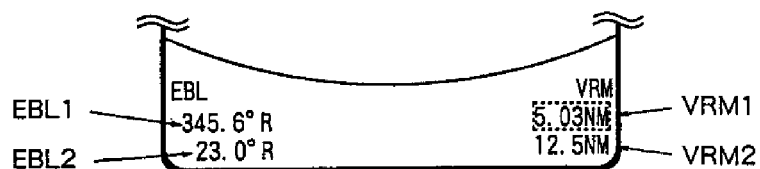

*Figure 1-8 Display bottom, showing location of EBL and VRM readouts*

- 2) Press the **CTRL** key to enable control of the VRM by the trackball.
- 3) Operate the trackball to place the outside edge of the VRM on the inside edge of the target.
- 4) Check the VRM readout at the bottom right-hand corner of the display to find the range to the target.
- 5) To anchor the VRM, press the **CTRL** key.

To erase the VRM and its readout, press and hold down the **CTRL** key about two seconds.

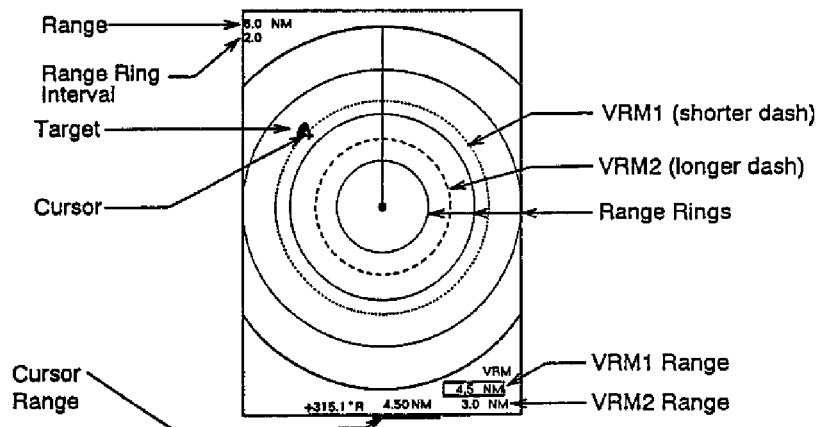

Figure 1-9 Measuring range by the cursor, range rings and VRM

■ **UNIT OF RANGE FOR VRM AND CURSOR:** You can display the range readout of the VRM and cursor in nautical miles, statute miles or kilometers, through the "Mode & Function" menu.

## Bearing

There are three ways to measure the bearing to a target:

- by the bearing scale (rough estimate)
- by the cursor, and
- by the EBL (Electronic Bearing Line).

### Cursor

Rotate the trackball to set the cursor intersection on the center of the target. The bearing to the cursor intersection appears at the bottom of the display.

### EBL

- 1) Press the **SELECT** key to circumscribe an EBL readout (at the bottom right-hand corner). Each press of the key selects the readout of VRM1, VRM2, EBL1 or EBL2 in that order.
- 2) Press the **CTRL** key to enable control of the EBL by the trackball.
- 3) Operate the trackball to bisect the target with the EBL.
- 4) Check the EBL readout at the bottom left-hand corner of the display to find the bearing to the target.
- 5) To anchor the EBL, press the **CTRL** key.

To erase the EBL and its readout, press and hold down the **CTRL** key about two seconds.

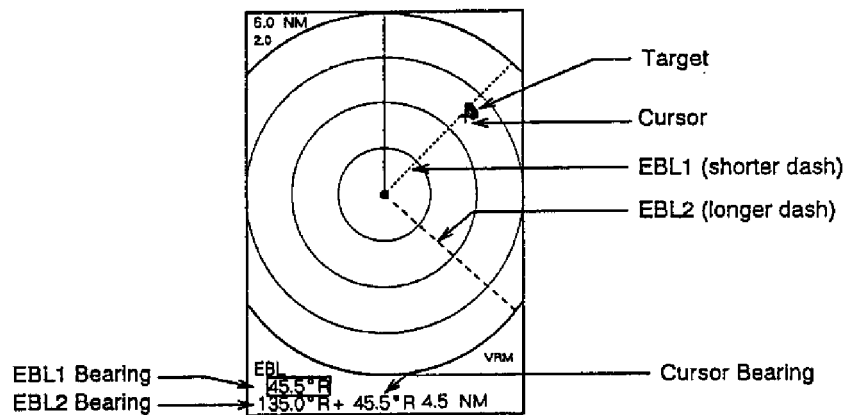

Figure 1-10 How to measure bearing by EBL and cursor



- **NOTE:** *The bearing readout for the EBL and the cursor can be displayed in relative or true bearing (true bearing requires heading sensor input), through the "Mode & Function" menu. For north up and course up display modes the bearing reference is always true.*

#### **Tips for measuring bearing**

- Bearing measurements of smaller targets are more accurate; the center of larger target pips is not as easily identified.
- Bearings of stationary or slower moving targets are more accurate than bearings of faster moving targets.
- To minimize bearing errors keep echoes in the outer half of the picture by changing the range scale; angular difference becomes difficult to resolve as a target approaches the center of the display.

#### **OUTPUTTING TARGET POSITION DATA**

Target position data can be output to external equipment in NMEA format. Press and hold down the GAIN control knob for 2 seconds to output the data. This function requires position data and heading signal.

## Using the Offset EBL

The offset EBL provides two functions: predict collision course of radar target and measure the range and the bearing between two targets.

### Predicting collision course

To predict collision course;

- 1) Press the **SELECT** key to choose EBL1 readout and then press the **CTRL** key.
- 2) Press the **EBL OFFSET** key. EBL1's origin shifts to cursor location.
- 3) Operate the trackball to place EBL1's origin (cursor) on the center of the target.
- 4) Operate EBL1 so it passes through the center of the display.
- 5) Wait several minutes. If the target tracks along EBL1 towards the center of the display (your vessel's position), it may be on a collision course.

To continue monitoring the target's track, press the **CTRL** key to anchor EBL1. To cancel the offset EBL, press the **EBL OFFSET** key.

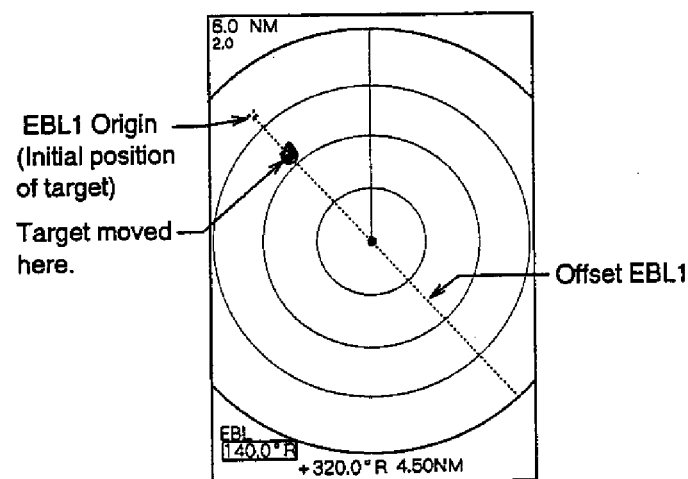
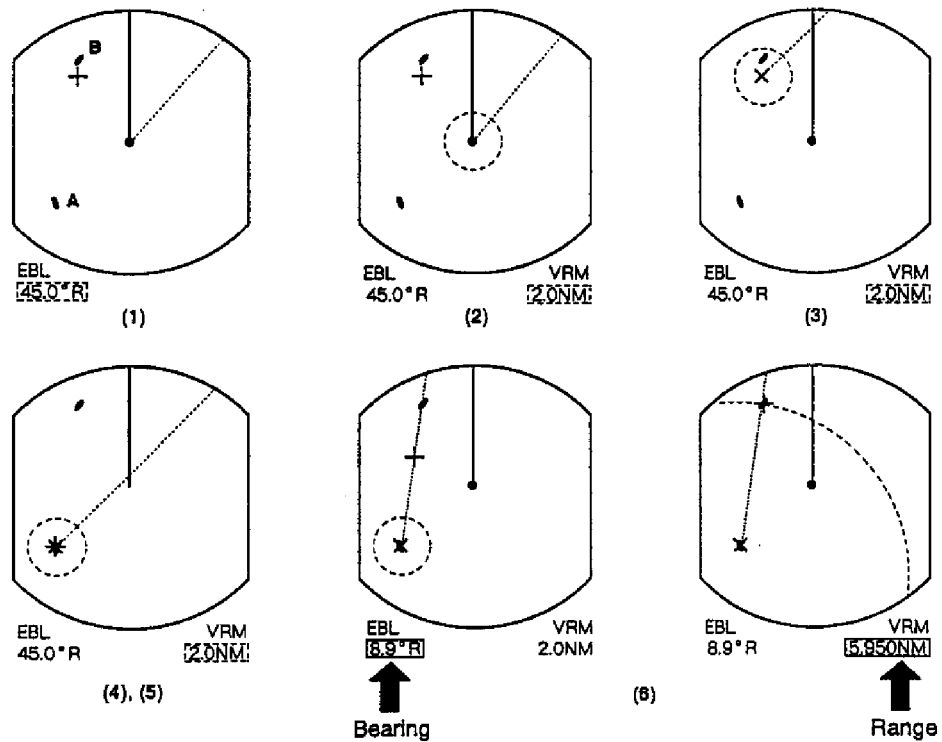

*Figure 1-11 Predicting collision course by using the offset EBL*

**Measuring range and bearing between two targets**

The procedure which follows shows how to measure the range and bearing between target "A" and target "B" in Figure 1-12.

- 1) Press the **SELECT** key to choose EBL1 readout and then press the **CTRL** key.
- 2) Press the **SELECT** key to choose VRM1 readout.
- 3) Press the **EBL OFFSET** key. EBL1's origin shifts to cursor location.
- 4) Operate the trackball to place EBL1's origin (cursor) on the center of target "A."
- 5) Operate the trackball to bisect target "B" with EBL1. Check the EBL1 readout to find the bearing between target "A" and target "B."
- 6) Press the **SELECT** key to choose VRM1 readout and then press the **CTRL** key. Operate the trackball to place the outside edge of VRM1 on the inside edge of target "B." Check the VRM1 readout to find the range between target "A" and target "B."



*Figure 1-12 Measuring the range and bearing between two targets by using the offset EBL*

## Reducing Interference

### Types of Interference

Basically there are three types of interference which may hinder radar reception:

- **sea clutter** caused by echoes reflected off waves (mentioned earlier)
- **rain clutter** from precipitation, and
- **radar interference** from marine radars operating nearby and on the same frequency band as your radar.

This radar can suppress or eliminate those types of interference. For how to reduce sea clutter see page 1-7.

### Rain clutter

The vertical beamwidth of the scanner is designed to see surface targets even when the ship is rolling. However, by this design the unit will also detect rain clutter (rain, snow, or hail) in the same manner as normal targets. Figure 1-13 shows the appearance of rain clutter on the display.

#### How to suppress rain clutter

- When only a slight amount of clutter is visible on the display, raise the **A/C SEA** control setting slightly to distinguish targets from the clutter.
- In heavy storms or partial clutter, adjust the **A/C RAIN** control. This control splits up these unwanted echoes into a speckled pattern, making recognition of solid targets easier.

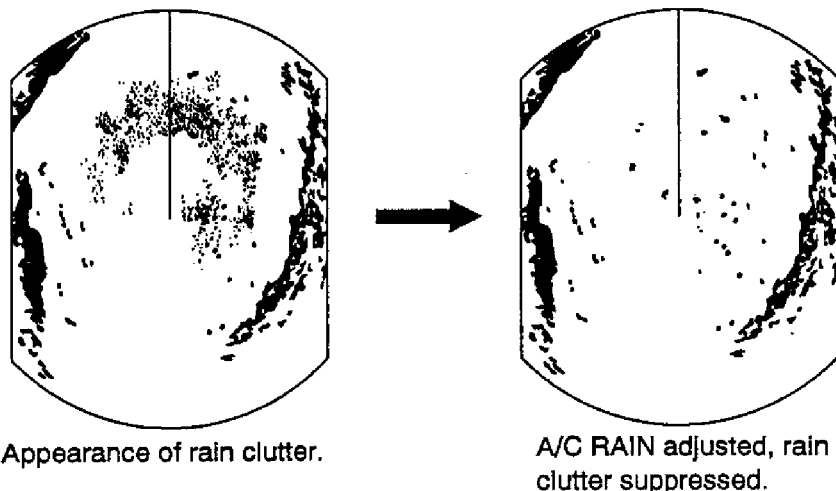

*Figure 1-13 Effect of A/C RAIN*

### Other uses of the A/C RAIN

In addition to reducing clutter, the **A/C RAIN** control can be used in fine weather to clarify the picture when navigating in confined waters. However, with the circuit activated the receiver is less sensitive. Therefore, turn the control fully counter-clockwise (off) when its function is not required.

### **Radar interference**

Radar interference may occur when near another marine radar operating in the same frequency band as your radar. Its on-screen appearance is many bright dots either scattered at random or in the form of dotted lines extending from the center to the edge of the display. Figure 1-14 illustrates interference in the form of "curved spokes." Interference effects are distinguishable from normal echoes because they do not appear in the same place on successive rotations of the scanner.

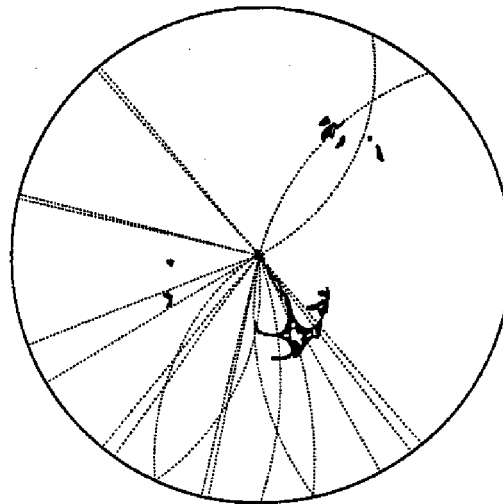

*Figure 1-14 Radar interference*

#### To reduce radar interference;

- 1) Press the **MENU** key to display the menu.
- 2) Operate the trackball to select "2. P/L & Int/Noise Rej."
- 3) Press the **CTRL** key.
- 4) Operate the trackball to select "2. Int Reject."
- 5) Operate the trackball to select level of interference rejection. ("IR" and level selected appear at bottom right-hand corner of the display.)
- 6) Press the **MENU** key twice to close the menu.

## Enlarging an Area of Interest (zoom)

The zoom feature allows you to double the size of the area between your vessel and any location within the current range to take a closer look at an area of interest without changing the range. Select location with the cursor, and then press the **ZOOM** key. "ZOOM" (blinking) appears at the top right-hand corner when the zoom function is on. To turn off zoom, press the key again.

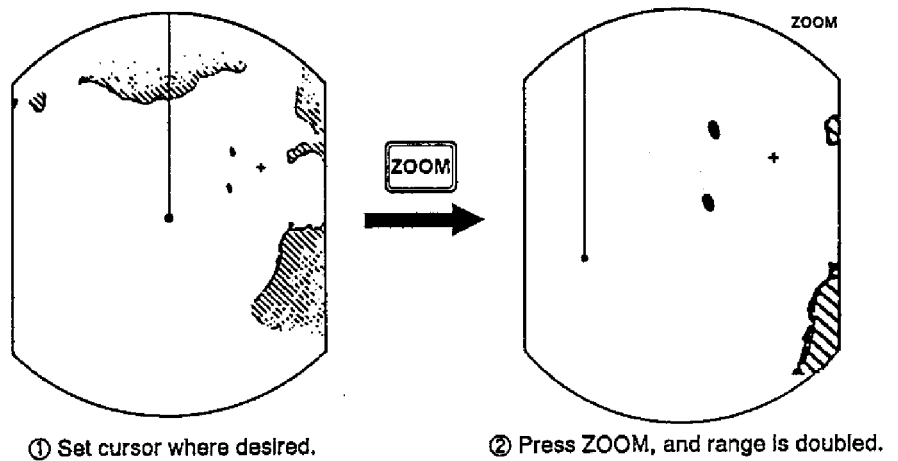

Figure 1-15 Zoom function

- **NOTE 1:** *The zoom function is inoperative when the display is shifted.*
- **NOTE 2:** *If the cursor is not positioned within the current range when the **ZOOM** key is pressed, several beeps are emitted and the outermost range ring blinks twice, even if the range rings are off. Reposition the cursor and press the key again.*

## Shifting the Picture (off center)

Your vessel's position can be shifted to view ahead or behind your vessel without changing the range or size of targets.

Operate the trackball to set cursor where desired, and then press the **OFF CENTER** key. "OFF CENTER" appears at the top right-hand corner of the display when the picture is shifted. To turn off the off center function, press the key again.

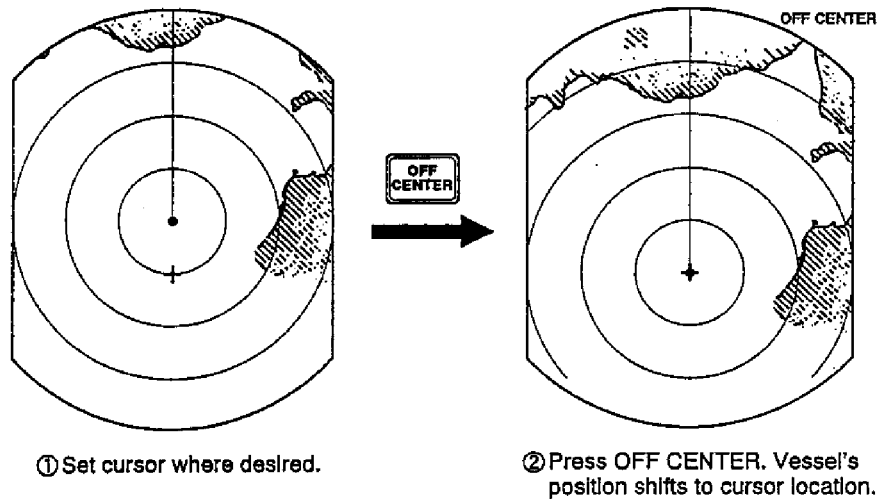

*Figure 1-16 Shifting the picture*

## Guard Alarm

The guard alarm allows the operator to set the desired range and bearing for a guard zone. When ships, islands, landmasses, etc. violate the guard zone an audible alarm sounds and the offending target blinks to call the operator's attention.

### Selection of guard zone type

The guard alarm can be set to sound when a target either enters or exits the guard zone. You can select which type of guard alarm you want through the "Mode & Function" menu.

#### In alarm

The alarm sounds on targets entering the guard zone. "G (IN)" appears at the top right-hand corner when the In alarm is selected.

#### Out alarm

The alarm sounds on targets exiting the guard zone. "G (OUT)" appears at the top right-hand corner when the Out alarm is selected.

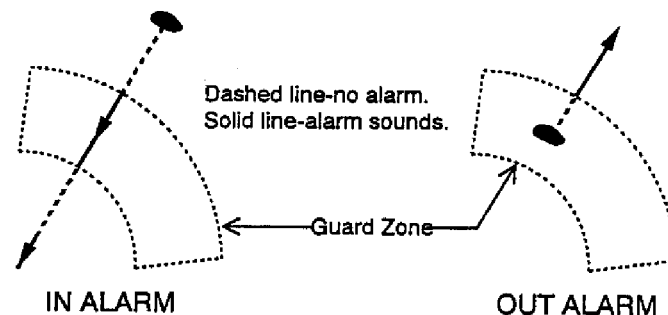

Figure 1-17 In and out alarms



## Setting a guard zone

### Preparation

- 1) Press the **MENU** key, and then select "Mode & Function" by operating the trackball and pressing the **CTRL** key.
- 2) Select "4. Alarm Mode" and "In" (alarm on target entering zone) or "Out" (alarm on target exiting zone) by operating the trackball.
- 3) Press the **MENU** key twice to close the menu.

### To set a guard zone;

- 1) Mentally create the guard zone you want to set.
- 2) Operate the trackball to set the cursor on point A or B. Press the **GUARD ALARM** key. "\*G (IN)" or "\*G (OUT)," with asterisk blinking, appears at the top right-hand corner of the display. See Figure 1-18 (2). (The asterisk indicates the guard zone is partially set.)
- 3) Operate the trackball to set the cursor on point C or D. See Figure 1-18 (3).
- 4) Press the **GUARD ALARM** key. The asterisk disappears. See Figure 1-18 (4).

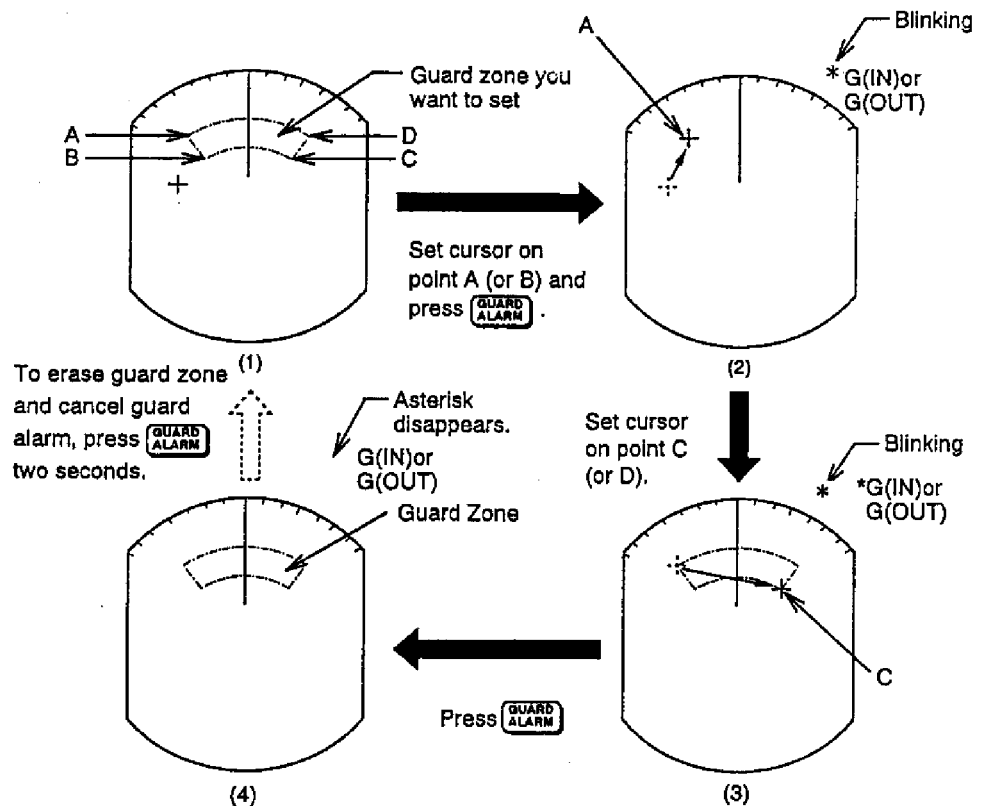

Figure 1-18 How to set the guard zone

### **Silencing the audible alarm**

Any radar targets violating the guard zone will trigger the audible alarm. You can silence the audible alarm by pressing the **GUARD ALARM** key. When this is done, “G (ACKN)” replaces “G (IN)” or “G (OUT).” This means the alarm is deactivated. Press the key again to reactivate the alarm.

### **Canceling the guard zone and guard alarm**

Press and hold down the **GUARD ALARM** key until the guard zone disappears.

### **Notes on the guard alarm**

- The alarm is a useful anti-collision aid, but does not relieve the operator of the responsibility to also keep a visual look-out for possible collision situations. The alarm should not be relied upon as the sole means for detecting possible collision situations.
- When the radar range is less than one half of the guard zone range, the guard zone disappears and “G (IN)” (“G (OUT)”) appears in inverse video. If this happens, raise the range to re-display the guard zone.
- A target echo does not always mean a landmass, reef, ships or surface objects but can imply returns from sea surface or precipitation. As the level of these returns varies with environment, the operator should properly adjust the **A/C SEA**, **A/C RAIN** and **GAIN** to be sure the alarm system does not overlook target echoes.
- The minimum echo strength which triggers the alarm can be selected through the “Installation Setup 1” menu.

## Trailing Target Movement (echo trail)

You can show the movement of all radar targets relative to your vessel in afterglow. This function is useful for alerting you to possible collision situations.

### Starting echo trailing

Press the **ECHO TRAIL** key to start echo trailing. Press the key again within three seconds to select echo trailing time, namely, trail length in minutes. Trailing time is available in 15 seconds, 30 seconds, 1 minute, 3 minutes, 6 minutes, 15 minutes, 30 minutes and continuous. "TRAIL," the echo trailing time selected and elapsed time appear at the top right-hand corner of the display. Then, afterglows starts extending from all targets.

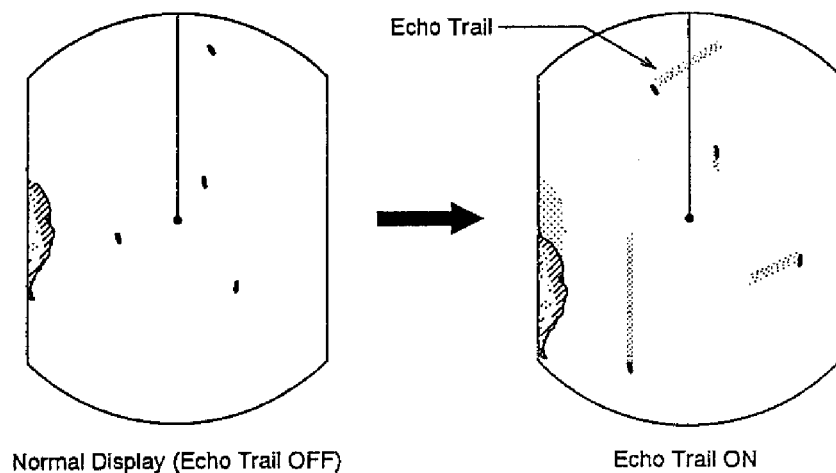

Figure 1-19 How the echo trail feature works

■ **NOTE:** If the range or mode is changed or the off center or zoom is turned on during echo trailing, trailing is restarted.

### Fixed time trailing

- 1) When the elapsed time clock counts up to the trailing time selected, the elapsed time display freezes.
- 2) The oldest portions of trails are erased so only the latest trail, equal in length to the trailing time selected, is shown.
- 3) Trailing continues.

For example, the one minute trailing time is selected. When the elapsed time clock counts up to 60 seconds, the elapsed time display freezes at "60," all but the latest one minute of trails are erased, and then trailing continues.

**Continuous trailing**

The maximum continuous trailing time is 99 minutes and 59 seconds. When the elapsed time clock counts up to that time the elapsed time display is reset to zero and trailing begins again.

**Adjusting brilliance of afterglow**

The brilliance of the afterglow can be set for high or low on the "Backlight/Brilliance" menu.

**Canceling echo trailing**

Press the **ECHO TRAIL** key.

## Displaying Navigation Data

Navigation data can be displayed at the screen bottom if this radar receives navigation input in NMEA 0183 format. Navigation data include

- position in latitude and longitude or Loran-C time differences (one can be selected on the “Nav Data” menu)
- range, bearing and time-to-go to both waypoint selected on the navigator and the cursor
- speed, and
- course.

(If the navigation input includes destination data, waypoint position is denoted on the radar display by a dashed ring.)

### To turn navigation data on or off;

- 1) Press the **MENU** key.
- 2) Operate the trackball to select the “Nav Data” menu.
- 3) Press the **CTRL** key.
- 4) Operate the trackball to select “2. Nav Data Disp.”
- 5) Operate the trackball to select ON or OFF.
- 6) Press the **MENU** key twice to close the menu.

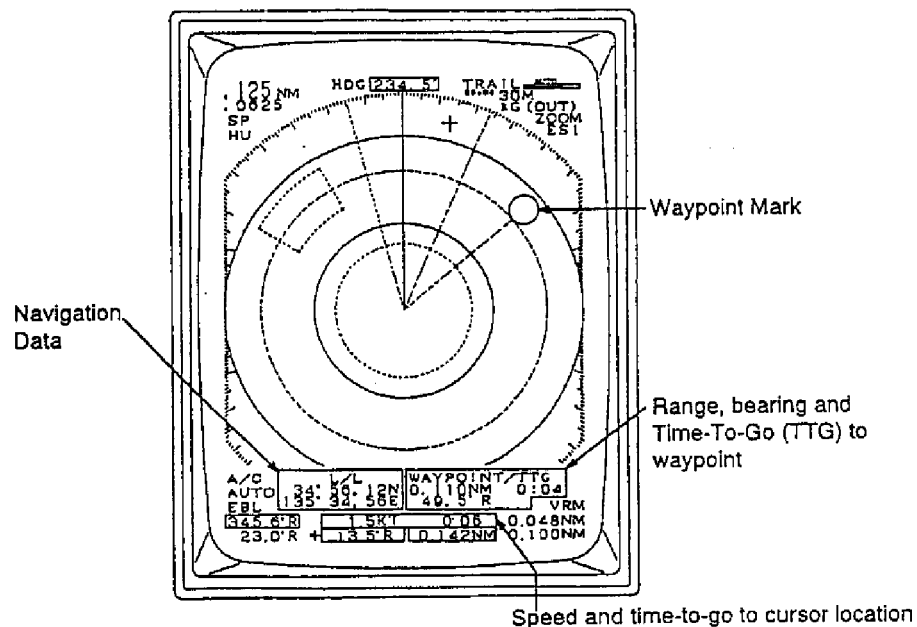

Figure 1-20 Typical navigation data display

## **Magnifying Long Range Echoes (echo stretch)**

---

Normally, the reflected echoes from long range targets appear on the display as weaker and smaller blips even though they are compensated by the radar's internal circuitry. The echo stretch function magnifies these small blips in all ranges. Two types of echo stretch are available: ES1 which stretches echoes in bearing direction and ES2 which stretches them in both range and bearing directions.

### **To turn the echo stretch on or off;**

Press the **A/C RAIN** control. Each press changes the echo stretch function in the sequence of ES1, ES2 and OFF. ES1 or ES2 appears at the top right-hand corner of the display when echo stretch is on.

- **NOTE:** *This function magnifies not only targets but also sea clutter and radar interference. For this reason be sure the controls for adjustment of sea clutter and radar interference are properly adjusted before activating the echo stretch.*

## Watchman

The watchman function periodically transmits the radar for one minute to check for targets in a guard zone. If it finds change in the zone from the previous transmission it sounds the audible alarm, cancels the watchman function, and transmits the radar continuously. This feature is useful when you do not need the radar's function continuously but want to be alerted to radar targets in a specific area.

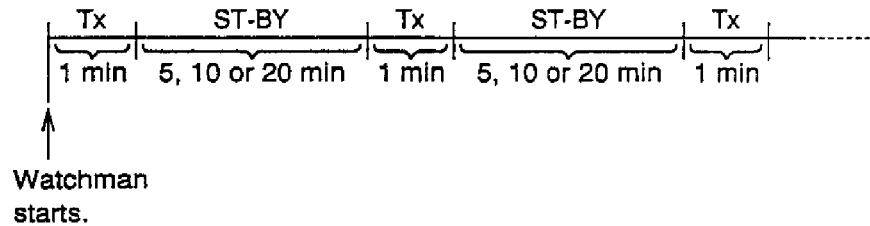

*Figure 1-21 How watchman works*

### Turning on watchman

#### To turn on watchman;

- 1) Create a guard zone (usually 360 degrees) with the guard alarm function.
- 2) Press the **MENU** key.
- 3) Operate the trackball to select "Mode & Function."
- 4) Press the **CTRL** key.
- 5) Operate the trackball to select "2. Watchman."
- 6) Operate the trackball to select watchman rest period; 5 minutes, 10 minutes or 20 minutes.
- 7) Press the **MENU** key twice to close the menu.

"WATCHMAN" appears at the top of the screen, the radar transmits for one minute to check for targets inside the guard zone, and then the CRT shuts off and the radar goes into stand-by.

### How watchman works

When the time selected for the watchman rest period has elapsed, the radar automatically transmits for one minute to check the condition inside the guard zone. If there is no change, the radar goes into stand-by ("WATCHMAN" appears during stand-by.) If there is change, the radar sounds the audible alarm, cancels the watchman function and transmits continuously.

**Canceling  
watchman**

Go into the “Mode & Function” menu, and set “2. Watchman” for OFF.

■ **NOTE 1:** *Watchman can be used without a guard zone.*

**2:** *The alarm sounds just before the radar starts and stops transmitting.*



# Summary of Display Indications

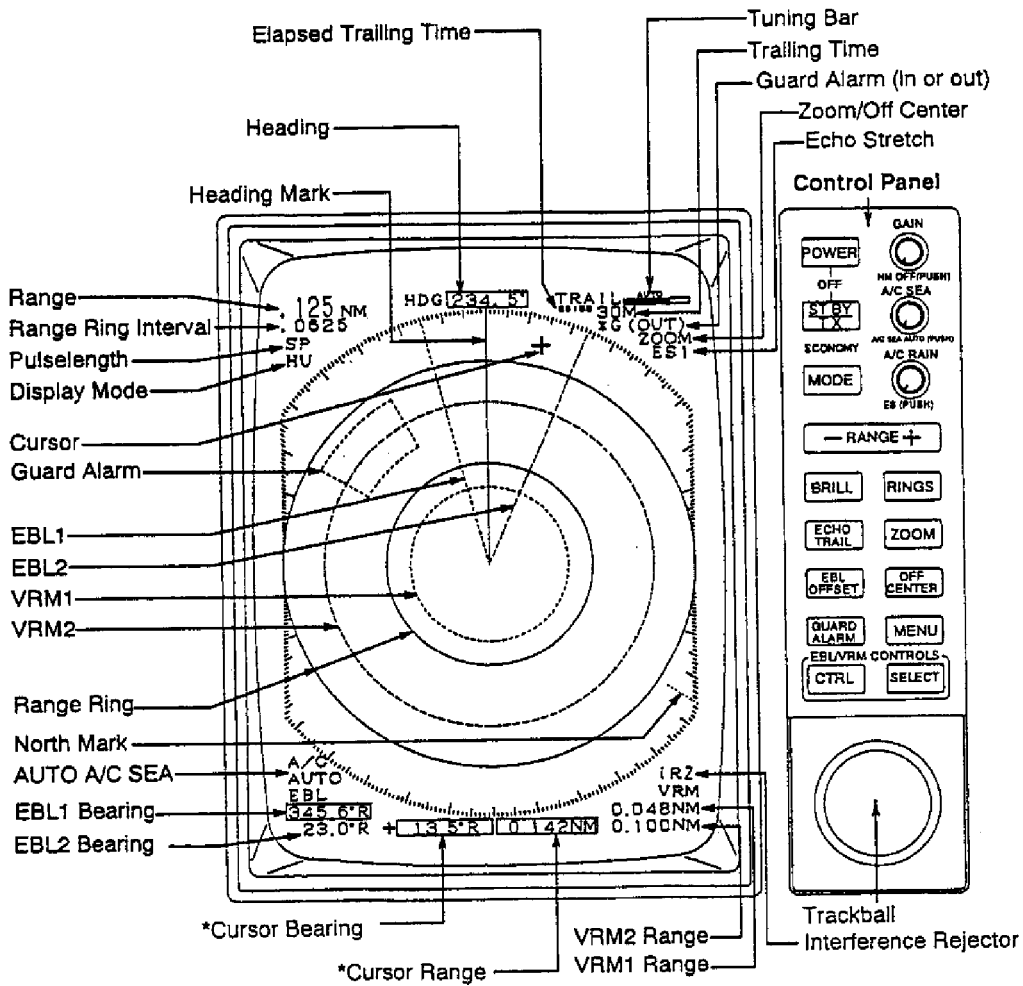

Figure 1-22 Display indications and marks

\* Latitude and Longitude of Cursor position can be displayed instead of Cursor range/bearing. Pressing the GAIN control (erasing heading marker) alternates the cursor position data display mode.

---

# APPLICATION

As an aid to navigation, radar can be a very valuable tool. No other navigation aid can give you the ability to spot vessels coming at you in the fog, or tell you the location of the inlet to the harbor in the pitch black of night.

To help you understand better what your radar can (and cannot) do for you this chapter covers

- the characteristics of the radar wave
- target properties and radar wave reflection
- range and bearing resolution
- false echoes, and
- position fixing with radar.

## The Radar Wave and Radar Horizon

### How the radar wave travels

The radar wave tends to travel in straight lines at the speed of light. However, it is subject to bending or refraction in the atmosphere, the amount depending on region and density.

#### Super-refraction

Super-refraction is a condition in which there is an upper layer of warm dry air over a surface layer of cold, moist air. Radar waves bend downward and thus increase the ranges at which targets may be detected.

#### Sub-refraction

Sub-refraction is the reverse condition of super-refraction; a layer of cold air is above a layer of warm air. Radar waves bend upward and thus decrease the ranges at which targets may be detected.

### Radar horizon

Radar is essentially a “line-of-sight” phenomenon. That means you have just about the same range to horizon with a radar as you do with your own eyes. However under normal atmospheric conditions, the radar horizon is 6% greater than the optical horizon. Therefore, if the target does not rise above the horizon the radar beam cannot be reflected from the target.

The distance to the horizon from the scanner, under normal conditions, is calculated by the following formula.

$$R_{\max} = 2.2 \times (\sqrt{h_1} + \sqrt{h_2})$$

Where  $R_{\max}$ : Radar horizon (mile),  $h_1$ : Antenna height (meters),  $h_2$ : Target height (meters)

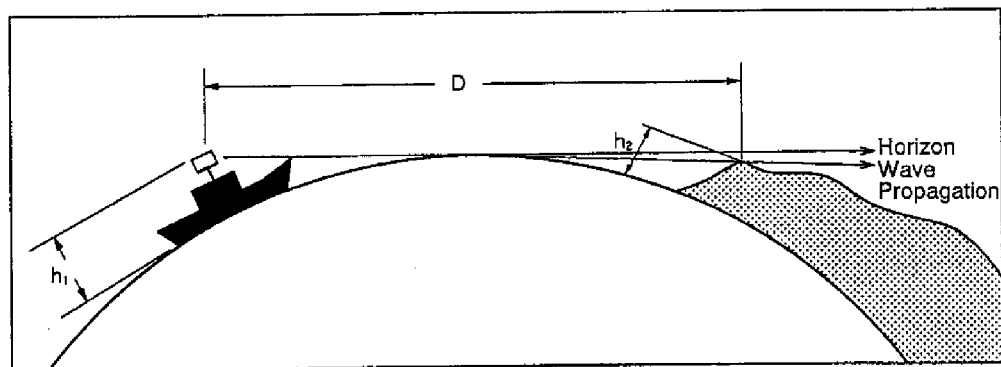

Figure 2-1 Radar horizon

## **Target Properties and Radar Wave Reflection**

---

Generally, larger targets can be seen on the radar display at greater ranges, provided line-of-sight exists between the scanner and target. However, a large target with poor reflecting properties may not be detected as easily as a smaller target with better reflecting properties. For example, you might expect a lighthouse to be a good radar target because of its size. In actuality the return echo is weak since the conical shape diffuses most of the radiated energy.

A ship whose hull is made of conducting materials, such as steel, will return a relatively strong echo.

On the other hand, hulls made from wood or fiberglass return much weaker echoes.

Vertical surfaces, such as a cliff, are good targets provided they face the radar. Conversely, horizontal and smooth surfaces such as mudbanks, sandy beaches, and gently sloping hills make poor targets because they disperse rather than reflect most of the energy that strikes them.

The strongest radar echoes known come from built-up areas, docks, etc., because these targets are less subject to changes in aspect. These types of targets have three flat, smooth surfaces mutually at right angles. Some radar buoys are arranged this way so as to deliberately increase their detection range.

## Range Resolution

Range resolution is a measure of the capability of a radar to display as separate pips the echoes received from two targets which are on the same bearing and are close together.

The main factor which affects range resolution is pulselength. Two targets on the same bearing, close together, cannot be seen as two distinct echoes on the display unless they are separated by a distance greater than one-half the pulselength.

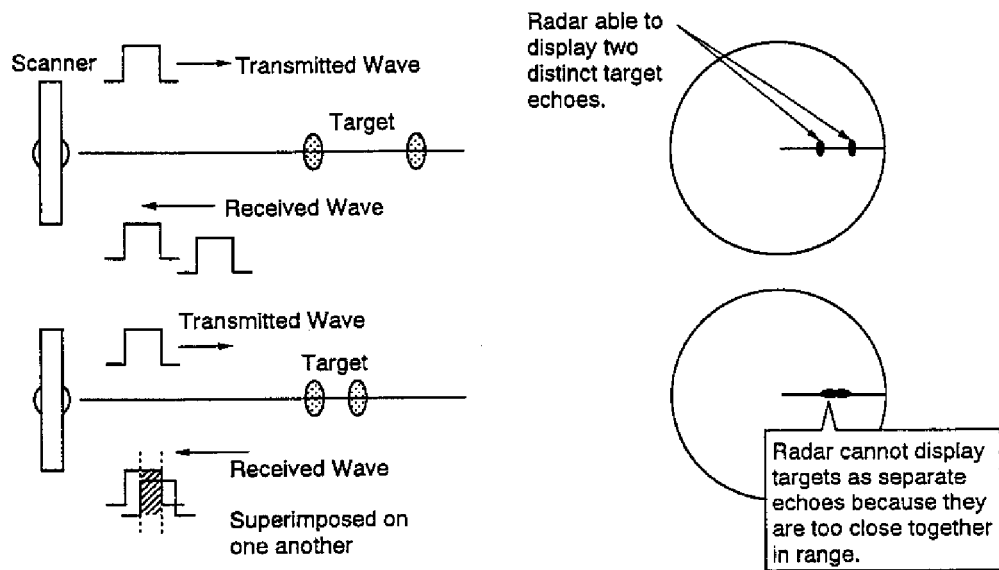
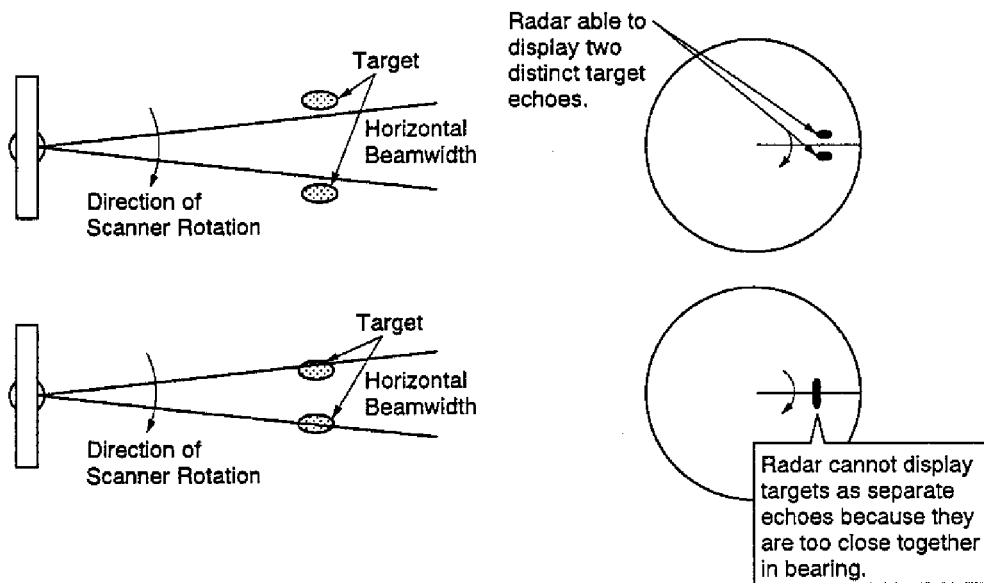

*Figure 2-2 Range resolution*

## Bearing Resolution

Bearing resolution is a measure of the capability of a radar to display as separate targets the echoes received from two targets which are at the same range and are close together.

The principal factor which affects bearing resolution is horizontal beamwidth. Two targets at the same range must be separated by more than one beamwidth to appear as separate pips.



*Figure 2-3 Bearing resolution*

## False Echoes

Occasionally false echoes appear on the screen at positions where there is no target. In some cases the effects can be reduced or eliminated. The operator should familiarize himself or herself with the appearance and effects of these false echoes, so as not to confuse them with echoes from legitimate contacts.

### Multiple echoes

Multiple echoes occur when a short range, strong echo is received from a ship, bridge, or breakwater. A second, a third or more echoes may be observed on the display at double, triple or other multiples of the actual range of the target as shown in Figure 2-4. Multiple reflection echoes can be reduced and often removed by decreasing the sensitivity or properly adjusting the A/C SEA.

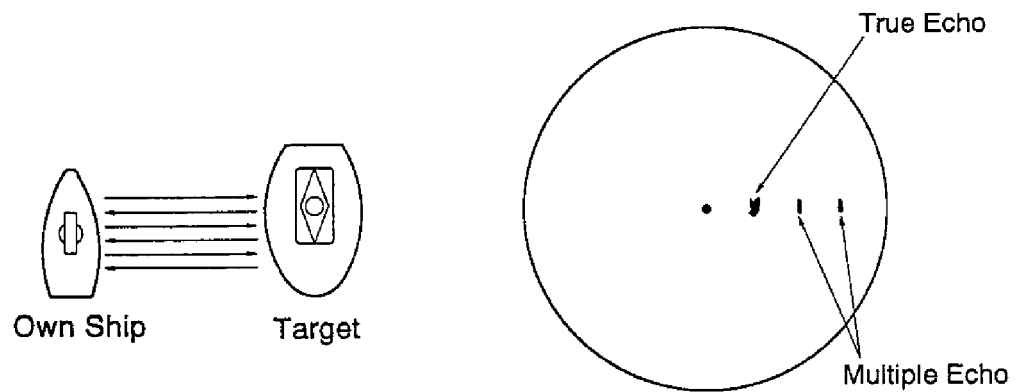

*Figure 2-4 Multiple echoes*

## Side-lobe echoes

Every time the scanner rotates, some radiation escapes on each side of the beam — called “side-lobes.” If a target exists where it can be detected by the side-lobes as well as the main-lobe, the side-lobe echoes may be represented on both sides of the true echo at the same range, as shown in Figure 2-5. Side-lobes show usually only at short ranges and from strong targets. They can be reduced through careful reduction of the sensitivity or proper adjustment of the A/C SEA.

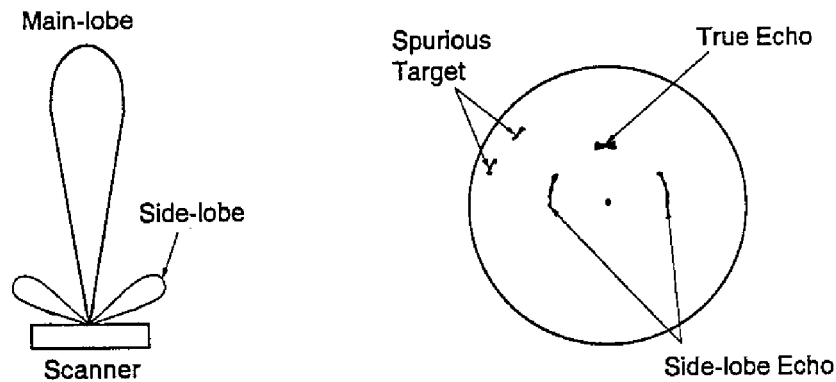

Figure 2-5 Side-lobe echoes

## Blind and shadow sectors

Funnels, stacks, masts, or derricks in the path of antenna may reduce the intensity of the radar beam. If the angle subtended at the scanner is more than a few degrees a blind sector may be produced. Within the blind sector small targets at close range may not be detected while larger targets at much greater ranges may be detected. See Figure 2-6.

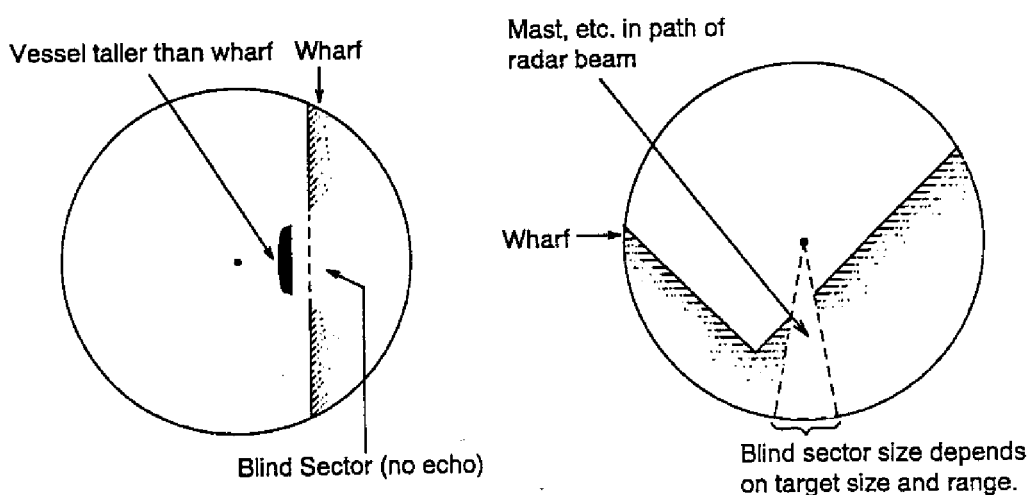

Figure 2-6 Blind and shadow sectors



## Indirect echoes

Indirect echoes may be returned from either a passing ship or returned from a reflecting surface on your own ship, for example, a stack. In both cases, the echo will return from a legitimate contact to the antenna by the same indirect path. The echo will appear on the same bearing of the reflected surface, but at the same range as the direct echo. Figure 2-7 illustrates the effect of an indirect echo. Indirect echoes may be recognized as follows:

- they usually occur in a shadow sector
- they appear on the bearing of the obstruction but at the range of the legitimate contact
- when plotted, their movements are usually abnormal, and
- their shapes may indicate they are not direct echoes.

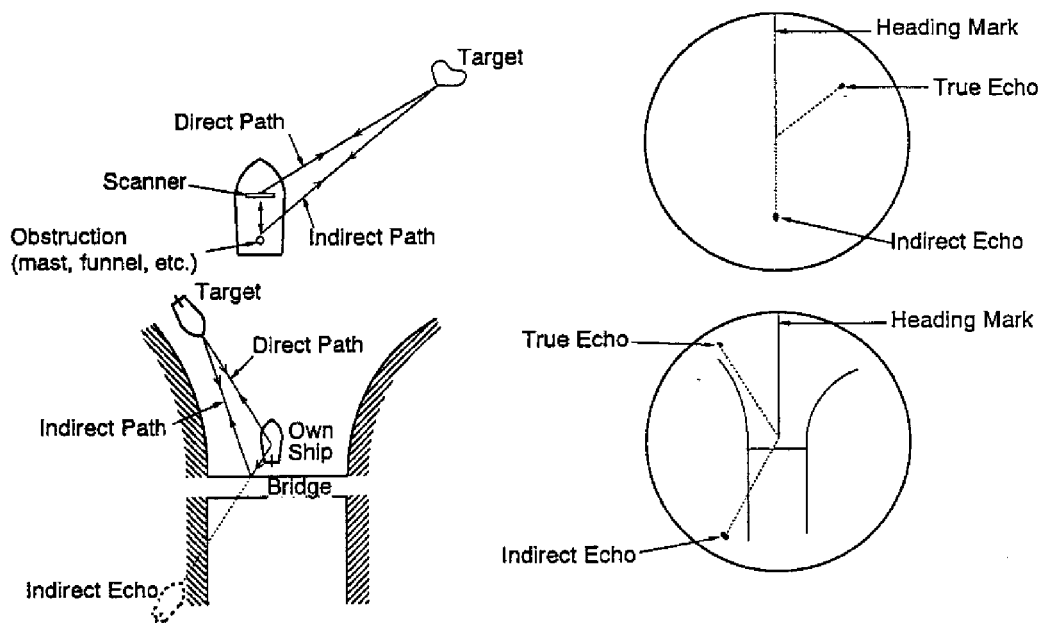

Figure 2-7 Indirect echoes

## Position Fixing with Radar

This section describes how to fix your position using the radar. You will need a compass and a navigation chart.

### By radar range

The simultaneous measurement of the ranges to two or more fixed objects is normally the most accurate method of obtaining a fix with radar alone. Preferably at least three ranges should be used. However the use of more than three range arcs may introduce excessive error because of the time lag between measurements, namely, you will be moving as you take successive measurements.

When obtaining a fix, it is best to measure the most rapidly changing range last because of a smaller time lag in the radar plot from the ship's actual position. For greater accuracy, the objects selected should provide arcs with angles of cut as close to 90 degrees as possible. Small, isolated, radar-conspicuous fixed objects whose associated range arcs intersect at angles approaching 90 degrees provide the most reliable and accurate position fixes. Objects at longer ranges are less accurate for position fixing because they may be below the radar horizon and because the width of the radar beam increases with range.

#### To fix your position by using radar range;

- 1) Measure the range to two or more prominent navigational marks which you can identify on the chart by the VRM.
- 2) Next, with the compass sweep out the ranges from the charted positions. The point of intersection of the arcs is your estimated position.

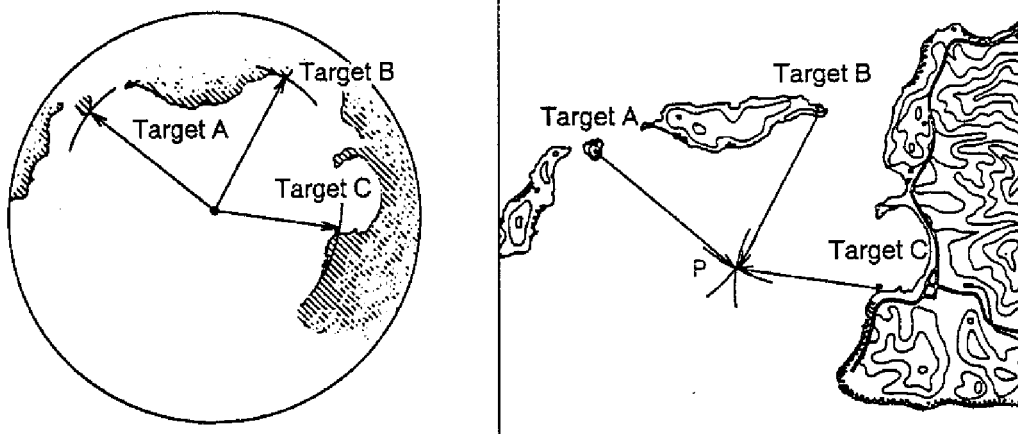

Figure 2-8 Position fixing using radar ranges

## By range and bearing to a point on land

The advantage of position fixing by range and bearing to a point of land is the speed with which a fix can be obtained. A distinct disadvantage however is this method is based upon only two intersecting position lines, a bearing line and range, obtained from two points of land. If possible, the object used should be small, isolated and identified with reasonable certainty.

### To fix your position using range and radar bearing;

- 1) Measure the relative bearing of the target with the EBL, noting the exact direction of the ship's heading when doing so.
- 2) Next, make allowance for compass deviation (true or magnetic) and find the true bearing of the target.
- 3) Sweep out the range to the target with the compass on the chart and plot the true bearing of the target. The point of intersection is your approximate position.

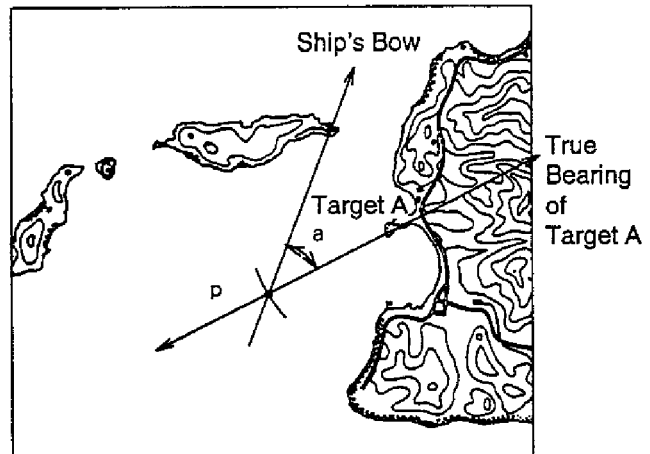
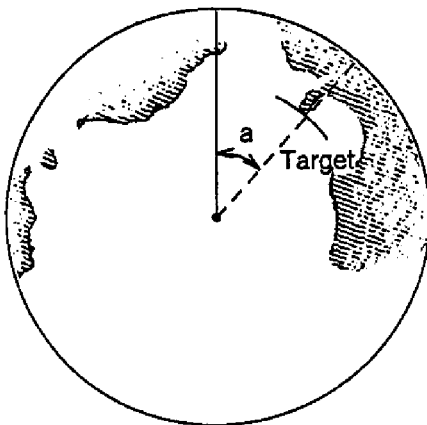

*Figure 2-9 Position fixing using range and bearing to a point of land*

## By two bearings

Generally, fixes obtained from radar bearing are less accurate than those obtained from intersecting range arcs. The accuracy of fixing by this method is greater when the center bearings of small, isolated radar-conspicuous objects can be observed. Similar to position fixing using range and bearing, this method affords a quick means for initially determining approximate position. The position should then be checked against other means to confirm reliability.

### To fix your position by using two radar bearings;

- 1) Measure the relative bearings for the two targets and then determine their true bearings.
- 2) Plot the two bearings on the chart. The point of intersection of the two bearings is your approximate position.

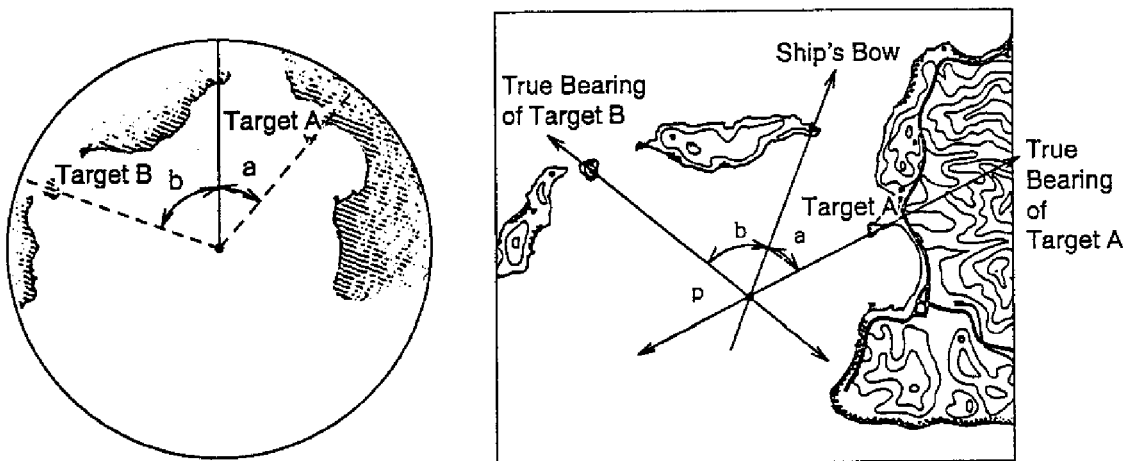

Figure 2-10 Position fixing using two bearings

## Nautical Chart and Radar Picture

Under normal conditions, a picture which is very similar to a nautical chart can be obtained on the radar display. However, a radar cannot:

- show targets which are below the horizon.
- show a target which is hidden by a larger one.
- see around corners (for example, seawall).
- distinguish between two targets which are very close together, either in range or bearing. For example, a vessel towing another will probably appear as one vessel, as both will be covered by the beam at the same time.

The nautical chart and radar picture shown in Figure 2-11 are from the Kaga Inland Sea in southwestern Japan.

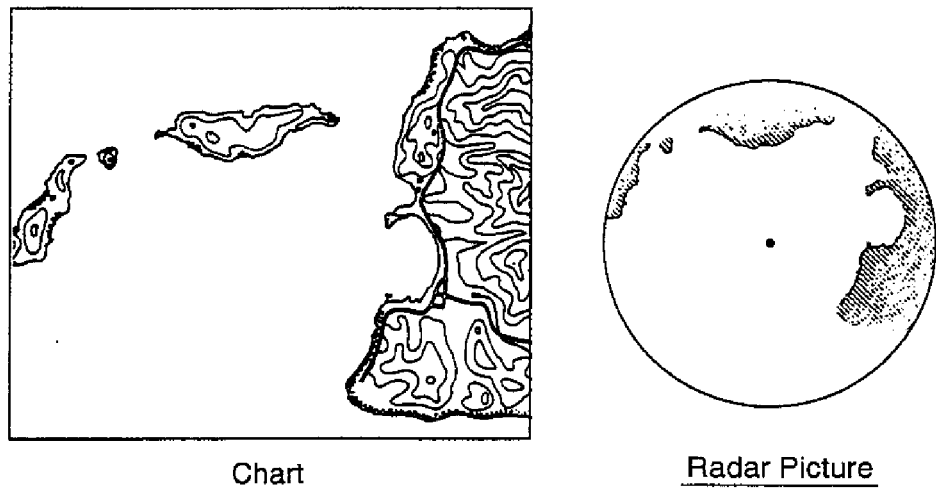

*Figure 2-11 Nautical chart and associated radar picture*

---

# MAINTENANCE

This chapter tells you how to keep your radar in good working order. Before reviewing this chapter please read the safety information which follows.

**Turn off the power before performing any maintenance procedures.**

## **DANGER: ELECTRICAL SHOCK HAZARD**

This equipment uses high voltage electricity which can endanger human life. At several places in the unit there are high voltages sufficient to kill anyone coming in direct contact with them. While the equipment has been designed with consideration for the operator's safety, precautions must always be exercised when reaching inside the equipment for the purpose of maintenance or service. For this reason, only qualified personnel totally familiar with electrical circuits and service manual should work inside the display unit or scanner unit.

## **CAUTION: RF RADIATION HAZARD**

The radar scanner emits high frequency radio radiation which can be harmful, particularly to your eyes. Never look directly into the scanner from a distance of less than two feet when the radar is in operation as you could injure the cornea of your eyes. Always make sure the radar is set to stand-by or is turned off before starting work on the scanner unit.

## Routine Maintenance, Location of Parts

### Maintenance program

Regular maintenance is important for good performance. Always keep the equipment as free as possible from dirt, dust, and water splashes. Make sure all screws securing the components are properly tightened.

A maintenance program should be established and should at least include the items listed in Table 3-1.

*Table 3-1 Maintenance program*

Period	Item	Checkpoint	Remarks
3 to 6 months	Scanner unit fixing bolts and nuts	Check for tightness and corrosion.	Replace corroded bolts. Apply coat of anti-corrosive sealant to new bolts.
	Radiator cleanliness	Foreign material (salt deposits, oil, etc.) on the radiator will cause a considerable drop in radar performance. Clean the radiator with a freshwater-moistened cloth.	The only recommended cleaning agent is alcohol.
	Antenna connectors	Open the scanner unit and visually check all connectors for proper seating and corrosion.	
	CRT	The CRT will, in time, accumulate a coating of dust which tends to dim the picture. Wipe the CRT lightly with a soft cloth to remove dust.	DO NOT use chemical cleaners to clean any part of the display unit. They may remove paint and markings.
6 months to 1 year	CRT anode and approach	High tension on CRT attracts dust, and moist dust will cause poor insulation.	<b>Have a qualified service technician clean CRT anode and approach. See Figure 3-2.</b>
1 year	Connectors on rear panel of display unit	Check connectors for proper seating and corrosion.	See Figure 3-3.

**Replacing the fuse**

The 5A (24 V/32 V) or 10 A (12 V) fuse on the rear panel of the display unit protects the equipment against reverse polarity of ship's mains, overcurrent, and equipment fault. If the fuse blows, find the cause before replacing it. Never use a fuse rated for more than 5A (or 10A), since overfusing can cause serious damage to the equipment and void the warranty.

**Location of parts**

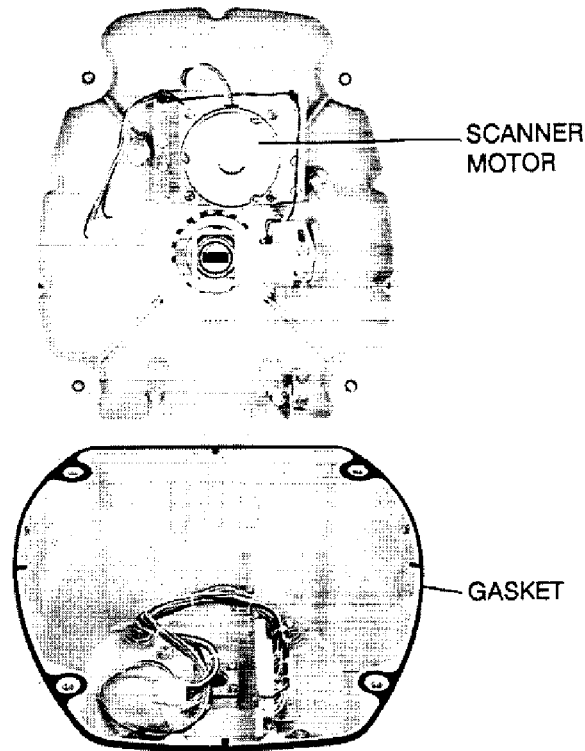

*Figure 3-1 Scanner unit, cover opened*



ANODE CAP  
(HIGH VOLTAGE)

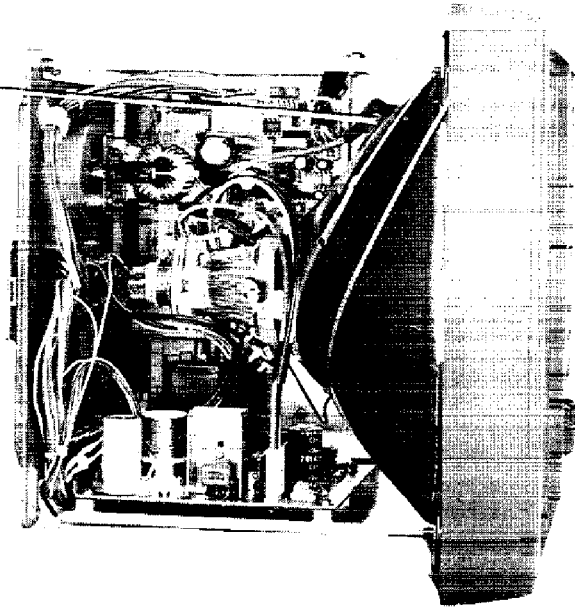

N Photo No.3082

Figure 3-2 Display unit, cover opened, top view

POWER FUSE F1351  
5A: 24V/32V DC  
10A: 12V DC

POWER  
CONNECTOR

DJ-1/DP-1

GROUND  
TERMINAL

N Photo No.3087

For optional equipment

GYRO CONNECTOR J1353  
NMEA CONNECTOR J1352

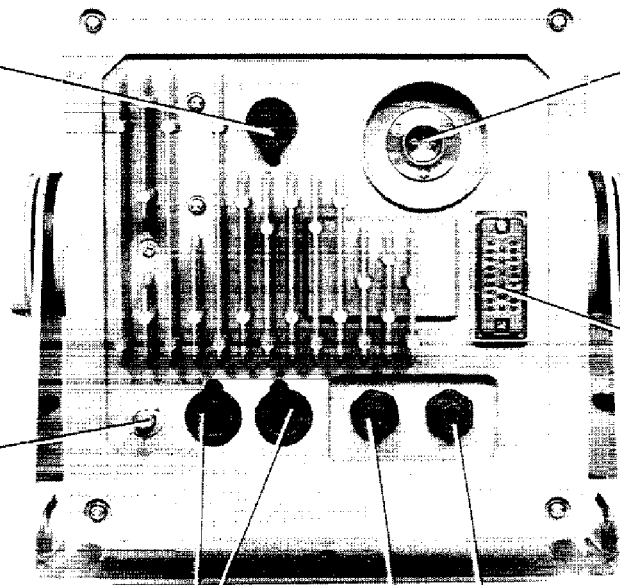

Figure 3-3 Display unit, rear view

---

# TROUBLESHOOTING

This section provides troubleshooting information for both the user and the service technician.

Before reviewing this chapter please read the safety information which follows.

## **TO THE USER**

If something appears to be wrong with your unit, check it by referring to the troubleshooting table. If you cannot restore normal operation, please do not attempt to check inside any unit. This equipment uses high voltage electricity which can cause severe injury or death. Any repair work is best left to a qualified technician.

## **TO THE SERVICE TECHNICIAN**

Always make sure the electrical power is turned off before attempting to change a component or inspecting the inside of the equipment. A residual charge may also exist in capacitors, even with the equipment turned off. Therefore, always short all supply lines to the chassis with an insulated screwdriver or a similar tool before touching the circuit.

## Troubleshooting Table

This section provides a troubleshooting table for use by both the user and the service technician.

*Table 4-1 Troubleshooting table*

IF...	BUT...	THEN...	
		User	Service Technician
	If the power is cut off because the power protection circuit has actuated, press the POWER and TX/OFF touchpads together, then press the POWER touchpad.		
	the control panel does not light	<ul style="list-style-type: none"> <li>● try raising display brilliance.</li> <li>● check fuse.</li> <li>● battery may have discharged.</li> </ul>	<ul style="list-style-type: none"> <li>● check fuse.</li> <li>● battery may have discharged.</li> <li>● measure voltage at power connector terminal #1 (+) and #2 (-) on FIL Board. It should be: 12V set: 10.2V to 20.3V DC 24V/32V set: 20.4V to 40.0V DC (See Figure 4-1 for location of FIL Board.)</li> <li>● check POWER Board.</li> <li>● check panel illumination lamps.</li> </ul>
	nothing appears on the display (panel lights)	<ul style="list-style-type: none"> <li>● try raising display brilliance.</li> </ul>	<ul style="list-style-type: none"> <li>● check CRT heater. If lit, CRT is normal.</li> <li>● check CRT high voltage by touching CRT anode cap to chassis.</li> <li>● adjust CONTRAST pot. R801 on CRT Board and BRIGHTNESS pot. R404 on DEFLECTION Board. If normal picture is achieved, CRT is normal.</li> <li>● check SPU Board.</li> </ul>
	picture is not synchronized		<ul style="list-style-type: none"> <li>● adjust V-HOLD pot. R510 and H-HOLD pot. L601 on DEFLECTION Board of CRT. If picture cannot be synchronized, CRT may be faulty.</li> <li>● check SPU Board.</li> </ul>

(Continued)

IF...	BUT...	THEN...	
		User	Service Technician
the radar has warmed up and you pressed the <b>STBY TX</b> key to transmit	the scanner does not rotate		<ul style="list-style-type: none"> <li>● check "Ant on Tx" in Installation Setup 1 menu; it should be set for "Rotate." (See procedure on next page.)</li> <li>● check scanner drive gears.</li> <li>● check scanner motor power circuit.</li> <li>● check scanner motor.</li> </ul>
	characters, indications are abnormal		<ul style="list-style-type: none"> <li>● check SPU Board.</li> </ul>
you adjusted sensitivity with both A/C RAIN and A/C SEA off (turned fully counterclockwise)	neither noise nor targets appear (indications and markers do)	<ul style="list-style-type: none"> <li>● check signal cable for damage.</li> </ul>	<ul style="list-style-type: none"> <li>● check signal cable for damage.</li> <li>● check IF amplifier.</li> <li>● check SPU Board.</li> </ul>
	neither indications nor marks appear (noise and targets do)	<ul style="list-style-type: none"> <li>● check signal cable for damage.</li> </ul>	<ul style="list-style-type: none"> <li>● check SPU Board.</li> <li>● check trigger line of signal cable for short.</li> <li>● measure magnetron current (voltage.) The magnetron current is measured as a voltage.                             <ol style="list-style-type: none"> <li>1) Transmit on max. range with scanner rotation suspended. (See procedure on next page.)</li> <li>2) Measure voltage at test point TP803 #5(+) and #6(-) on MD Board in scanner. Voltage should be 0.9V to 1.1V DC. Replace magnetron if voltage is not within that range.</li> </ol> </li> <li>● check modulator circuit.</li> </ul>
	the sweep is not synchronized with scanner rotation		<ul style="list-style-type: none"> <li>● check bearing pulse generator circuit in scanner.</li> <li>● check SPU Board.</li> </ul>

(Continued)

IF...	BUT...	THEN...	
		User	Service Technician
you adjusted sensitivity	there is no change in sensitivity		<ul style="list-style-type: none"> <li>● measure magnetron current (voltage) as described on previous page. Replace magnetron if its voltage is not within range prescribed on previous page.</li> <li>● MIC is out of tune.</li> </ul>
a key is pressed	nothing happens		<ul style="list-style-type: none"> <li>● key may be faulty.</li> <li>● check SPU Board.</li> </ul>

**To transmit with scanner rotation suspended;**

- 1) Turn off the power.
- 2) While pressing and holding down the **GAIN** control (hold at least three seconds) press the **POWER** key.
- 3) Press the **MENU** key.
- 4) Operate the trackball to select "7. Installation Setup 1," and then press the **CTRL** key.
- 5) Operate the trackball to select "4. Ant on Tx" and "Stop."
- 6) Press the **MENU** key twice to close the menu.

# Location of Parts

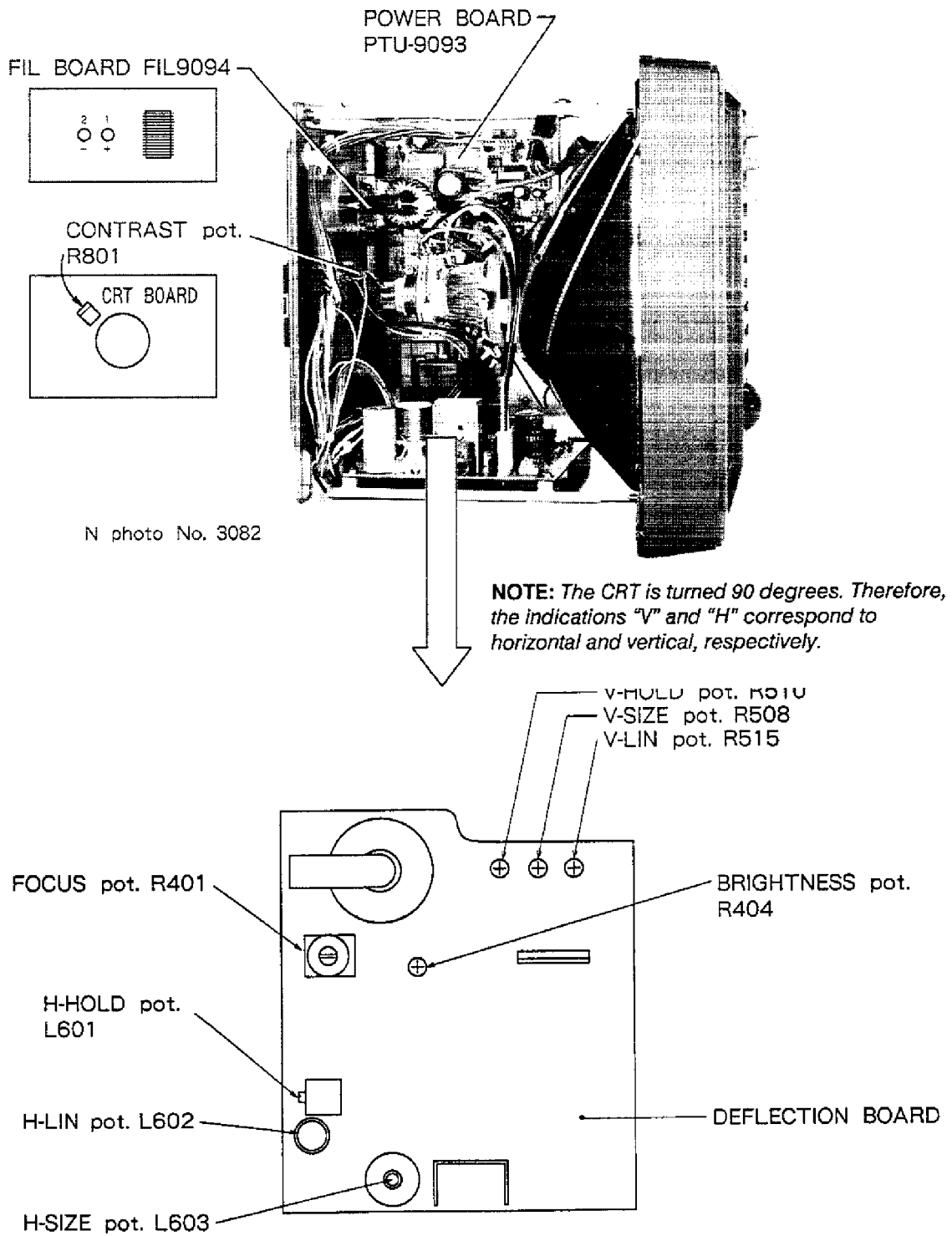

Figure 4-1 Display unit, cover removed, left side view

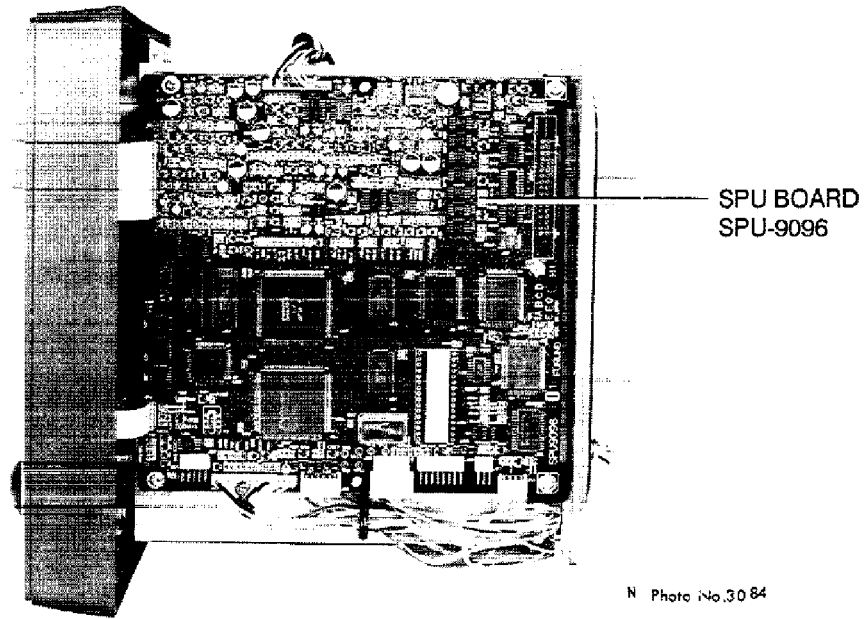

Figure 4-2 Display unit, cover removed, right side view

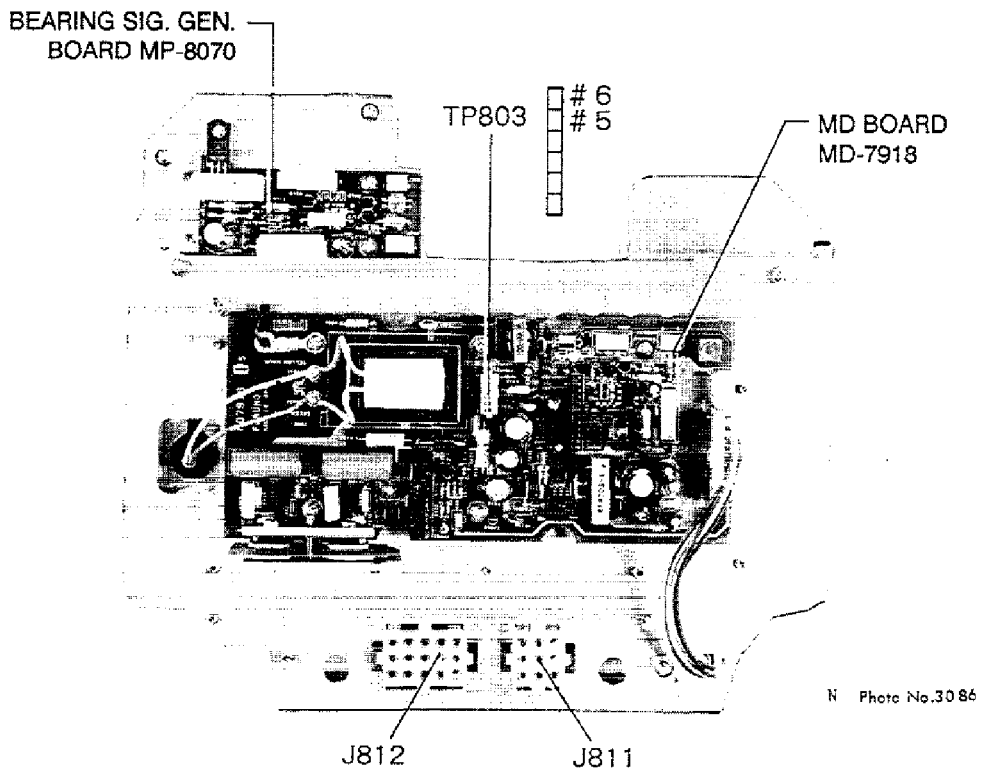

Figure 4-3 Transceiver module, bottom view, cover removed

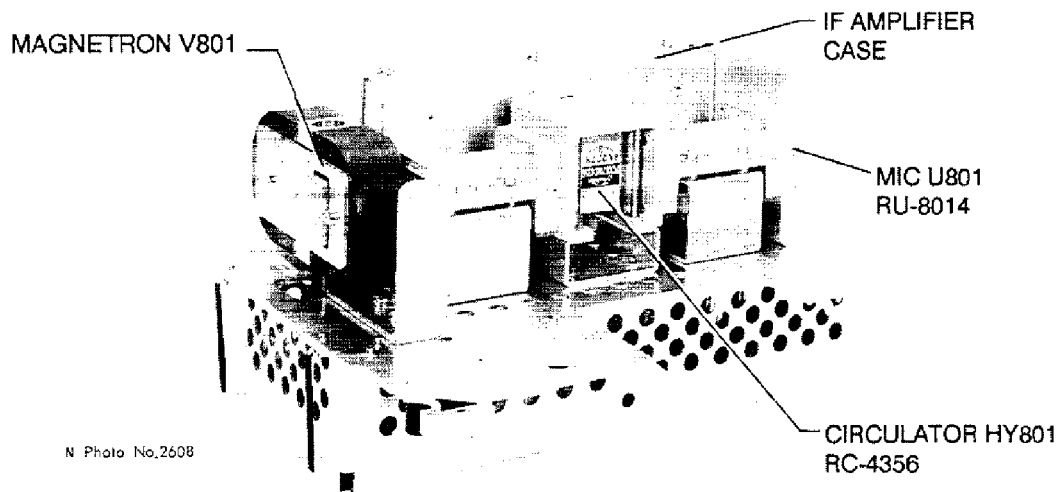

Figure 4-4 Transceiver module

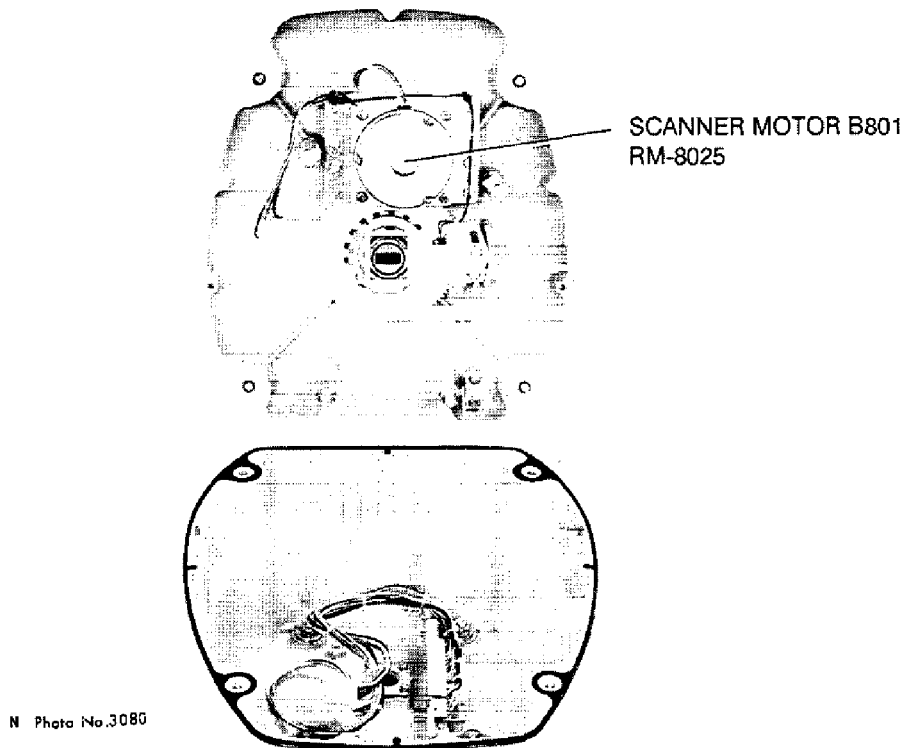

Figure 4-5 Scanner unit, cover opened



*This page intentionally left blank.*

---

# INSTALLATION

This chapter provides the procedures necessary for installation. Installation mainly consists of the following:

- siting and mounting the display unit and the scanner unit
- connection of the signal cable and the power cable
- establishing the ground
- connection of optional equipment
- checking the installation, and
- adjustments.

## Scanner Unit Installation

---

### Siting, handling considerations

- The scanner unit is generally installed either on top of the wheelhouse or on the radar mast on a suitable platform. Locate it where there is a good all-round view with, as far as possible, no part of the ship's superstructure or rigging intercepting the scanning beam. Any obstruction will cause shadow and blind sectors. A mast for instance, with a diameter considerably less than the width of the scanner, will cause only a small blind sector, but a horizontal spreader or cross-trees in the same horizontal plane as the scanner unit would be a much more serious obstruction; you would need to place the scanner unit well above or below it.
- It is rarely possible to place the scanner unit where a completely clear view in all direction is available. Thus, you should determine the angular width and relative bearing of any shadow sectors for their influence on the radar at the first opportunity after fitting. (The method of determining blind and shadow sectors appears later in this chapter.)
- If you have a radio direction finder on your boat, locate its antenna clear of the scanner unit, to prevent interference to the direction finder. A separation of more than two meters is recommended.
- To lessen the chance of picking up electrical interference, avoid where possible routing the signal cable near other onboard electrical equipment. Also avoid running the cable in parallel with power cables.
- The compass safe distance of 1.1 meter (standard compass) and 0.8 meter (steering compass) should be observed to prevent deviation of the magnetic compass.
- The scanner base is made of aluminum, which will corrode if the mounting platform is made of iron. For this reason paint the mounting platform if it is made of iron.
- Do not paint the radiator aperture, to ensure proper emission of the radar waves.
- Do not lift the scanner unit by the radiator.
- When this radar is to be installed on larger vessels, consider the following points
  - The signal cable run between the scanner and the display unit comes in lengths of 10m, 15m, 20m and 30m. Whatever length is used it must be unbroken; namely, no splicing allowed.
  - Deposits and fumes from a funnel or other exhaust vent can adversely affect the aerial performance and hot gases may distort the radiator portion. The scanner unit must not be mounted where the temperature is more than 70°C.

## Mounting

- 1) Drill four fixing bolt holes (13 millimeters dia.), one cable entry hole (approx. 50 millimeters dia.) in the mounting platform. See the scanner outline drawing on page D-2 for hole dimensions.
- 2) Detach the scanner housing cover from the scanner housing by loosening four fixing bolts. The scanner housing cover fitted with the transceiver module can be stored in a convenient place until the wiring to the scanner unit is done.
- 3) Place the scanner housing on the mounting platform and orient it as shown in Figure 5-1(a).

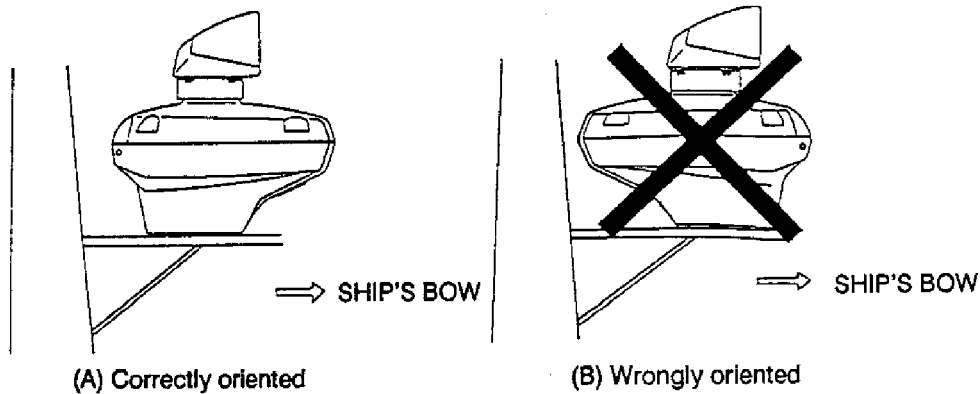

*Figure 5-1 How to orient the scanner unit*

- 4) Insert four M12 × 60 hex head bolts with the seal washers from inside the scanner housing, to prevent the bolts from contacting the transceiver module. Install the seal washer with the larger diameter next to the head of the bolt. Coat flat and spring washers and nuts and then use them to fasten the scanner housing to the mounting platform. Finally, coat exposed parts of nuts, bolts and flat and spring washers as shown in Figure 5-2.

■ **NOTE:** Do not turn the bolt to secure the scanner housing. Tighten the bolts by the nut to prevent damage to the seal washer.

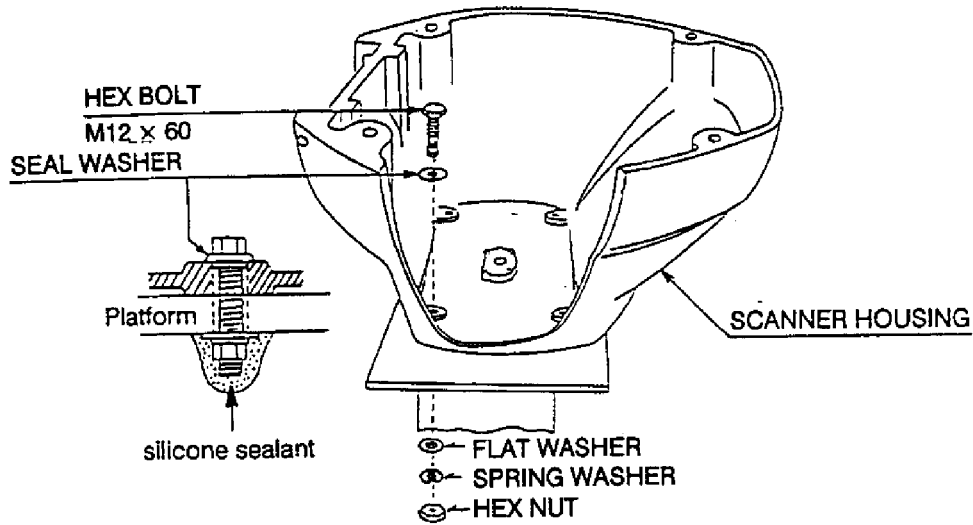

Figure 5-2 How to mount the scanner housing

## Connections

Only the signal cable runs from the display unit to the scanner unit. Make the hole for passing the cable through the bulkhead or deck at least 20 millimeters diameter. In order to minimize the chance of picking up electrical interference, avoid where possible routing the signal cable near other onboard electrical equipment. Also, avoid running the cable in parallel with power cables. Pass the cable through the hole and apply sealing compound around the hole for waterproofing.

The procedure for connecting the signal cable to the scanner unit is as follows.

- 1) Through a pipe or waterproof cable gland fitted on the wheelhouse top or bulkhead.
- 2) Unfasten four screws at bottom of the scanner base to remove the cable gland assembly.
- 3) Pass the signal cable through the scanner base and the cable gland assembly (removed in step 2.)

■ **Note:** If the antenna unit comes with a signal cable RW-6537 (larger in diameter), instead of RW-8577-1, replace the packing with the one supplied.

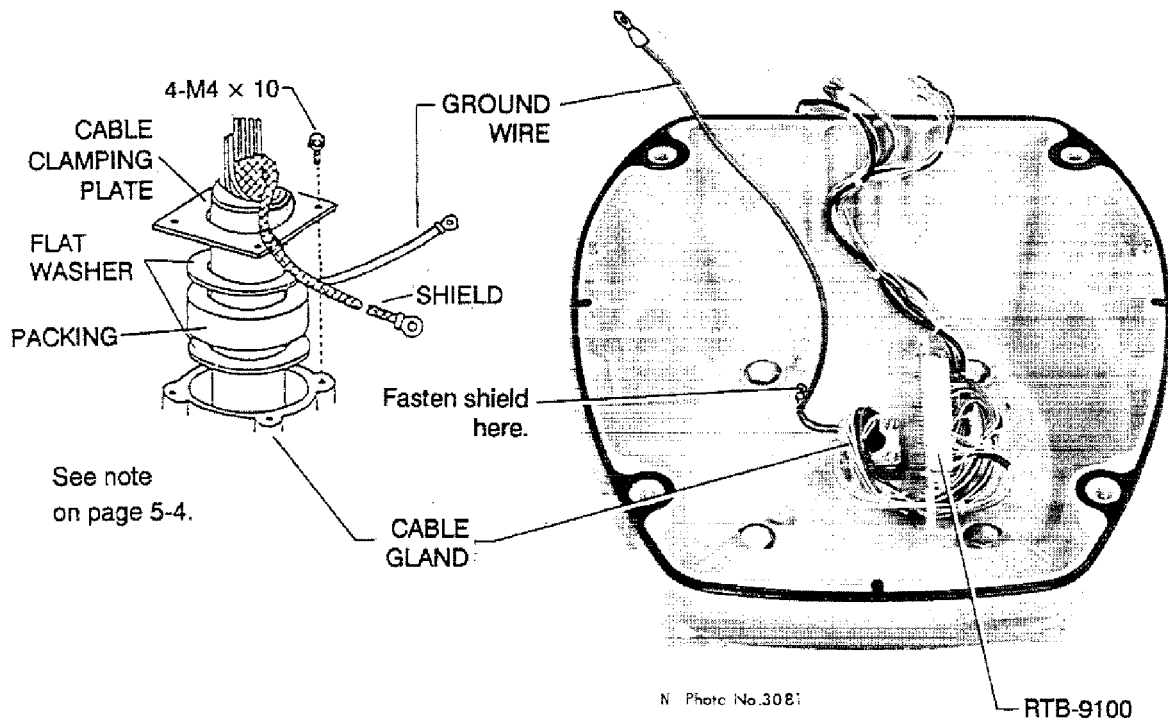

Figure 5-3 Passing the signal cable through the scanner housing

- 4) Secure the cable gland to the scanner base for complete watertightness.
- 5) Connect the lead wires to RTB-9100 in the scanner housing by referring to the interconnection diagram on page S-1. Fasten the shield (inner and outer combined) at the bottom of the scanner housing as shown in Figure 5-3.

**Final preparation**

- 1) Place the scanner housing cover onto the scanner housing. Loosely fasten the four fixing bolts on the cover.

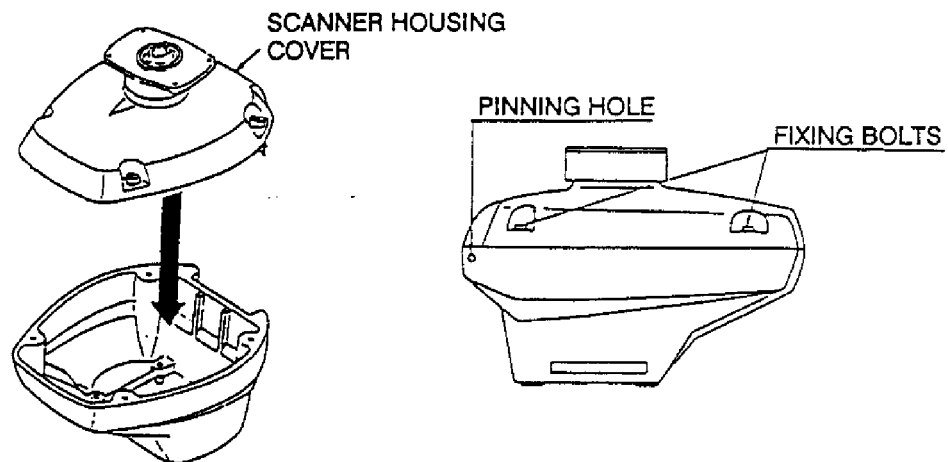

Figure 5-4 Fastening the scanner housing cover

- 2) Apply grease to the two slot pins. Using a wooden hammer to prevent damage to paint, inset slot pins into the pinning holes until the pin head is flush with the scanner housing surface.

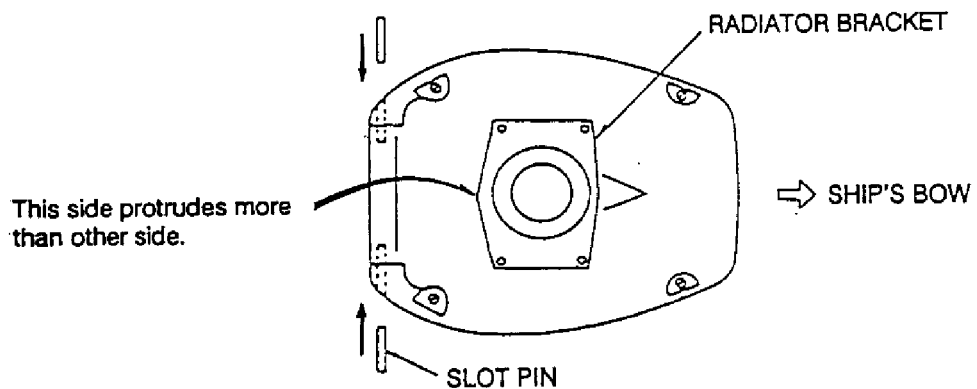

Figure 5-5 How to insert slot pins

- 3) Now is the time to fix the radiator to the radiator bracket. Remove the waveguide cap on the radiator bracket and orient the radiator bracket as shown in Figure 5-6. Referring to Figure 5-7, apply grease to the O-ring and set it to the center of the radiator bracket. Coat the radiator fixing bolts with silicone sealant. Fasten the radiator to the radiator bracket with the FURUNO logo on the radiator facing ship's bow.

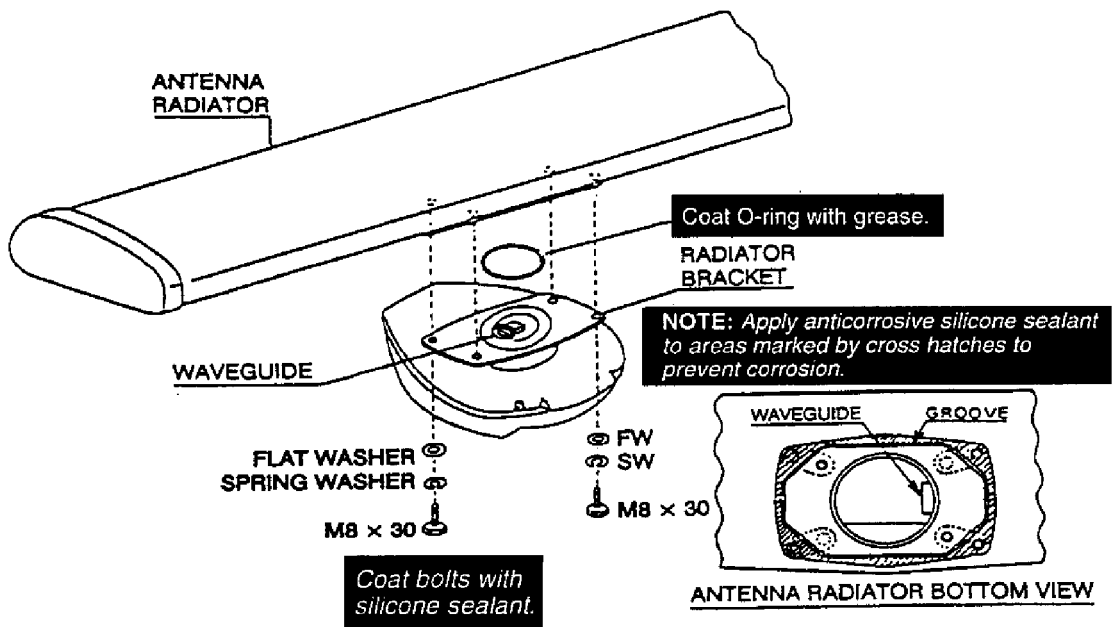
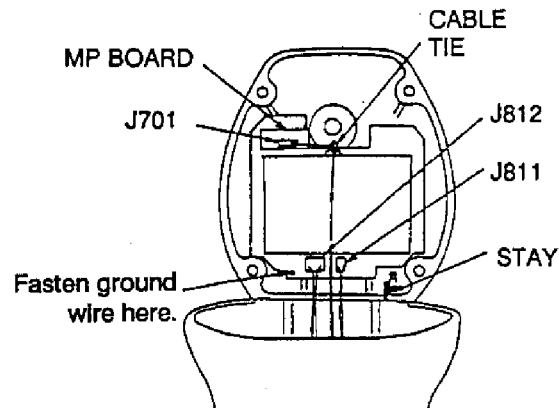

Figure 5-6 Fastening the radiator to the radiator bracket

- 4) Open the scanner housing cover and fix the stay as shown in Figure 5-7.



*Figure 5-7 Scanner unit, cover opened*

- 5) One end of the cable with 15-, 9- and 7-way plugs has already been connected to RTB-9100 inside the scanner housing. Mate the 15- and 9-way plugs with jacks J812 and J811 on the transceiver module, respectively. Connect the 7-way plug to jack J701 on the MP Board. Secure the cable between RTB-9100 and J701 with the cable tie as shown in Figure 5-7.
- 6) Fasten the ground wire (black) of the signal cable to the chassis as shown in Figure 5-7.
- 7) Loosely fasten the scanner housing cover. You will tighten the fixing bolts after confirming magnetron heater voltage.



## Display Unit Installation

---

### Mounting considerations

When selecting a mounting location for the display unit keep in mind the following points.

- The display unit is carefully constructed to be able to withstand the humidity and corrosive atmosphere common in a pilothouse, but it is not designed to be used outside, exposed to the environment.
- If this radar is to be installed on a small boat, the display unit must be mounted inside an enclosed cabinet to prevent corrosion of the connectors on the rear of the display unit. For maximum protection against corrosion by salt spray, tape the connectors and seal them with putty compounds.
- Provide adequate space behind and around the unit to permit circulation of air and to provide convenient access to the rear connectors.
- Even though the picture is quite legible even in bright sunlight, keep the display unit out of direct sunlight or at least shaded because of heat that can build up inside the cabinet.
- Locate the display unit in a position where you can view and operate it conveniently but where there is no danger of salt or fresh water spray or immersion.
- The orientation of the display unit should be so the radar screen is viewed while the operator is facing in the direction of the bow. This makes determination of your position much easier.
- Make sure you allow enough clearance both to get to the connectors behind the unit and to allow you to get your hands in on both sides to loosen or tighten the mounting knobs. Make sure you leave at least a foot or so of "service loop" of cables behind the unit so it can be pulled forward for servicing or easy removal of the connectors.
- The compass safe distance of 0.8 meters (standard compass) and 0.6 meters (steering compass) should be observed to prevent deviation of the magnetic compass.



**Connections**

- 1) Connect the power cable to connector J1351 on the rear of the display unit.
- 2) Connect the signal cable to connector DJ-1 on the rear of the display unit.
- 3) Run a ground wire (local supply) between the ground terminal on the rear of the display unit and the ship's superstructure.

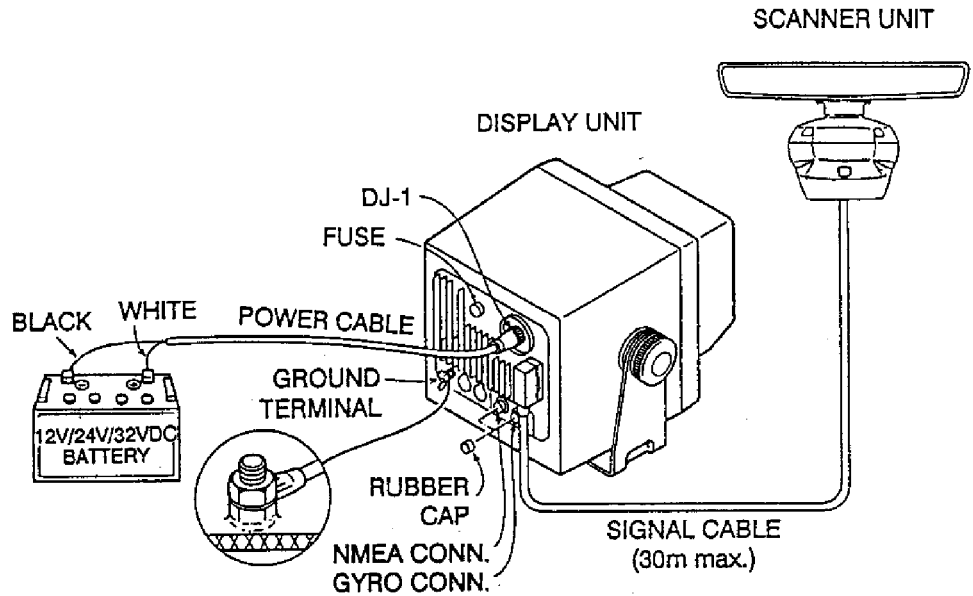

*Figure 5-9 Connections on the display unit*

**Exchange of fuse for 24V/32V power supply**

The display unit is shipped from the factory with a 10A fuse fitted in the fuse holder on the rear panel. This fuse is for use with a 12V DC power supply. For 24V/32V DC power supply, replace the fuse with the 5A fuse (supplied).

## Connection of External Equipment

**Heading sensor** With heading sensor connection (for example, FURUNO C-2000), you can display true bearing for ship's heading, cursor and EBLs. The FURUNO C-2000 Heading Sensor comes with a heading sensor cable. One end of the cable is prefitted with a connector. Connect it to the GYRO connector on the rear panel of the display unit. How to attach a connector to the other end of the cable and connection to the C-2000 are described in the operator's manual of the C-2000.

**Navigator** If your navigator outputs navigation data in NMEA 0183 format, your vessel's position in latitude and longitude, ship's speed, and range and bearing to waypoint may be output to this radar, and be shown in the bottom text area.

**Echosounder** The depth data from the echosounder can be connected to J54 on the SPU Board, using EH Connector assembly supplied.  
 (An optional cable provides connectors at both ends, cut out the connector at the radar end and solder the EH connector supplied; Pins #1 and #2 of E/S are connected to pins #3 and #4 of J54 respectively.)

Optional Cables:

Type	Code no.	Remarks
MJ-A6SPF0012-050	000-134-424	For navaid, 5 m, 6P-6P
MJ-A6SPF0012-100	000-133-817	For navaid, 10 m, 6P-6P
MJ-A6SPF0011-050	000-132-244	For E/S, 5 m, 6P-4P
MJ-A6SPF0011-100	000-132-336	For E/S, 10 m, 6P-4P

## Checking the Installation

---

After completing the installation, it is a good idea to recheck it to be sure all steps were correctly done. Use the installation check list below to check the installation.

*Table 5-1 Installation check list*

Tick box

- The signal cable is waterproofed at the scanner base.
- The signal cable is securely retained against the mast or mounting platform and is free of interference from running rigging.
- The cable gland or entry on the deck, if provided, is waterproofed.
- The power connections to the battery are of correct polarity.
- The plugs at the rear of the display unit are tightly fastened.
- The fuse on the rear panel of the display unit is 10A (12V) or 5A (24V/32V DC).

---

## Adjustments

---

This section covers adjustment of the radar after installation. You will need to

- enter antenna height
- align heading
- adjust sweep timing
- confirm magnetron heater voltage, and
- measure blind and shadow sectors.

### Entering antenna height, aligning heading, adjusting sweep timing

#### Preparation

These adjustments are done through the installation setup menus.

- 1) Turn off the radar. While pressing and holding down the **GAIN** control (at least three seconds) press the **POWER** key.
- 2) When “ST-BY” appears, press the **STBY TX** key to transmit.
- 3) Select maximum range and adjust the **GAIN** control so the background noise is just visible on the display.
- 4) Press the [-] key several times to select the minimum range. Adjust the **A/C SEA** to display nearby radar targets clearly on the screen. Too much A/C SEA action will eliminate small targets, and too little A/C SEA action will cause the screen to be so full of targets and noise that it is hard to determine which target is which compared to visual sightings.

**Entering antenna height**

The STC curve changes with respect to antenna height above the waterline. Enter antenna height above the waterline to optimize the STC curve.

- 5) Press the **MENU** key to display the menu.

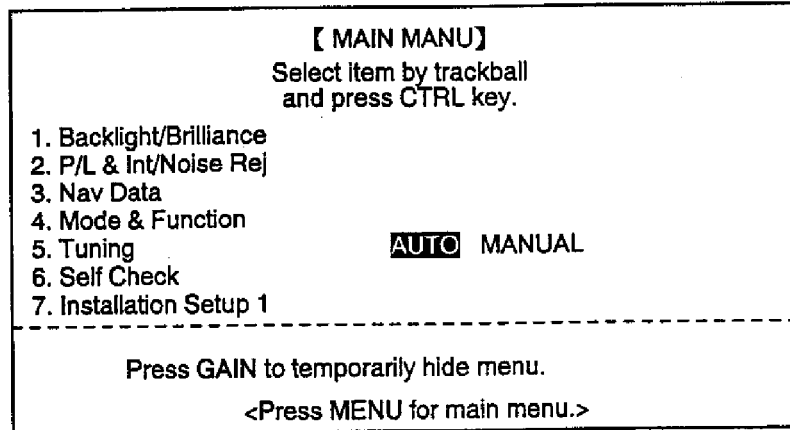

*Figure 5-10 Menu*

- 6) Operate the trackball to select “7. Installation Setup 1,” and then press the **CTRL** key.

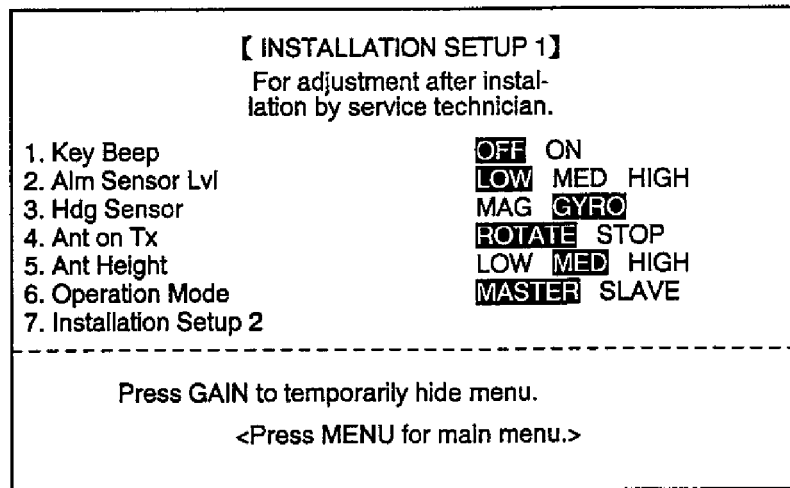

*Figure 5-11 Installation setup 1 menu*

- 7) Operate the trackball to select “5. Ant Height.”
- 8) Operate the trackball to select antenna height above the waterline; low, medium or high.
- 9) Press the **CTRL** key.

### Aligning heading

You have mounted the scanner unit facing straight ahead in the direction of the bow. Therefore, a small but conspicuous target dead ahead visually should appear on the heading mark (zero degrees).

In practice, you will probably observe some small error on the display because of the difficulty in achieving accurate initial positioning of the scanner unit. The following adjustment will compensate for this error.

- 10) Identify a suitable target (for example, ship or buoy) at a range between 0.125 to 0.25 nautical miles, preferably near the heading mark. To lessen error, keep echoes in the outer half of the picture by changing the range. Also, be sure the zoom and off center functions are off.
- 11) Operate the trackball to select "7. Installation Setup 2," and then press the **CTRL** key.

[ INSTALLATION SETUP 2 ]	
For adjustment after installation by service technician.	
1. Align Heading	
2. Adjust Sweep Timing	
3. On Hours	000001.5H
4. Tx Hours	000000.3H
-----	
Press GAIN to temporarily hide menu.	
<Press MENU for inst setup 1.>	

*Figure 5-12 Installation setup 2 menu*

- 12) Operate the trackball to select "1. Align Heading," and then press the **CTRL** key. EBL1 appears on the display.
- 13) Operate the trackball to bisect the target selected at step 10 with EBL1, and then press the **CTRL** key.
- 14) As a final test, move the boat towards a small buoy and confirm that the buoy shows up dead ahead on the radar when it is visually dead ahead.



### Adjusting sweep timing

This adjustment ensures proper radar performance, especially on short ranges. The radar measures the time required for a transmitted echo to travel to the target and return to the source. The received echo appears on the display based on this time. Thus, at the instant the transmitter is fired, the sweep should start from the center of the display (sometimes called sweep origin.)

A trigger pulse generated in the display unit goes to the scanner unit through the signal cable to trigger the transmitter (magnetron). The time taken by the signal to travel up to the scanner unit varies, depending largely on the length of signal cable. During this period the display unit should wait before starting the sweep. When the display unit is not adjusted correctly, the echoes from a straight local object (for example, a harbor wall or straight pier) will not appear with straight edges—namely, they will be seen as “pushed out” or “pulled in” near the picture center. The range of objects will also be incorrectly shown.

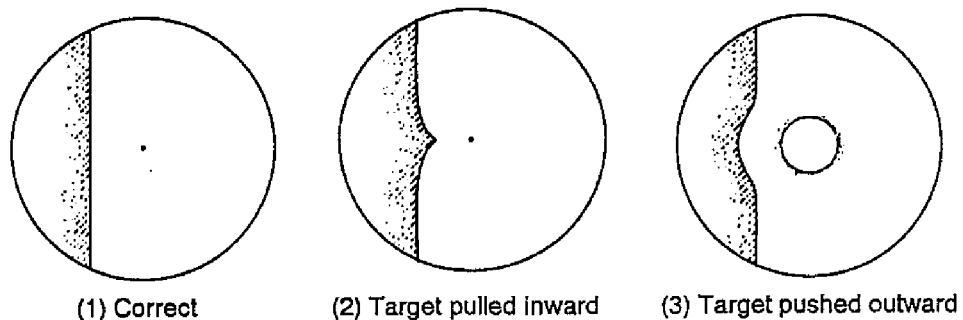

*Figure 5-13 Examples of improper and correct sweep timings*

- 15) Transmit on the shortest range and confirm that the **GAIN** and **A/C SEA** controls are properly adjusted.
- 16) Visually select a target which forms right angles (harbor wall, straight pier).
- 17) Press the **MENU** key.
- 18) Operate the trackball to select “2. Adjust Sweep Timing,” and then press the **CTRL** key.
- 19) Operate the trackball to straighten target selected at step 16, and then press the **CTRL** key.
- 20) Press the **MENU** key four times to close the menu.

**Magnetron heater voltage**

Magnetron heater voltage is formed at the MD Board of the scanner unit and preadjusted at the factory for use with any length of signal cable. Therefore no adjustment is required. However, verify heater voltage by following the procedure below.

- 1) Turn on the radar (if it is not already on) and set it in stand-by.
- 2) Open the scanner housing cover. Connect a multimeter, set to 10V DC range, between #5(+) and #6(-) of test point TP803 on the MD Board in the scanner unit.
- 3) Confirm that the multimeter shows  $7.6V \pm 0.1V$ . If it does not, adjust potentiometer VR801 on the MD Board.
- 4) Close the scanner housing cover and tighten the fixing bolts.

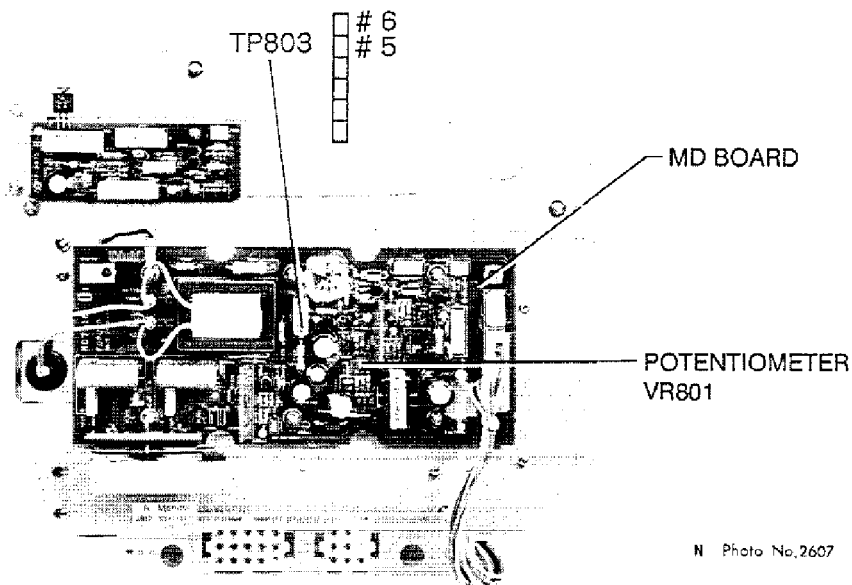

*Figure 5-14 Transceiver module, bottom view, cover removed*

**Measuring blind and shadow sectors**

In some shadow sectors, there may not be sufficient intensity to obtain an echo from very small targets even at close range, although a large vessel may be detected at a much greater range in non-shadowed sectors. For these reasons the angular width and relative bearing of any shadow sectors should be determined. For a new vessel this should be done during sea trials. In other ships it should be done at the first opportunity after installing the radar.

Even a small shadow sector may hide another vessel if she is on a collision course with your vessel. The bearing will remain constant in the shadow area and the approach of the other vessel may remain undetected until it is too late to avoid a dangerous situation.

Two methods of determining the angular width of a shadow sector are:

- Turn the boat very slowly through 360 degrees while a small but clearly defined target is observed at a distance of a mile or so. (Do not use a buoy with a reflector as this target is too powerful to achieve the required result.)

If the echo disappears while the boat is turning, the target has entered a shadow sector and it will again become visible when the target emerges from the shadow. Very quiet conditions of wind and sea are essential to ensure reliable results when this operation is carried out on a small craft since a rough sea can cause a buoy to be lost in the clutter or be temporarily submerged or hidden by waves. An unsteady movement may cause the boat to swing through a shadow sector before the scanner has completed one revolution. In any case an average of several observations of each shadow sector should be taken. It is a waste of time to attempt the operation in anything other than very smooth water with little wind.

- Another method is to observe the shadow sector against a background of sea clutter. Any shadows will show as dark sectors in the clutter. See Figure 5-15.

Note that a shadow cannot be fairly estimated in heavy clutter, as echoes from either side of the sector may be spread into it and give an illusion that objects in the sector are being observed. Nor can it be satisfactorily determined in confined waters, because of the probability of indirect, false or multiple echoes being produced from nearby building or other vessels.



SHADOW CAUSED  
BY MAST

*Figure 5-15 Appearance of a shadow sector on the display*

The result of the above measurement should be recorded on a blind shadow sector diagram. Figure 5-17 is an example of a shadow sector diagram for the scanner unit sited in Figure 5-16. The blind sector diagram should be fixed near the display unit.

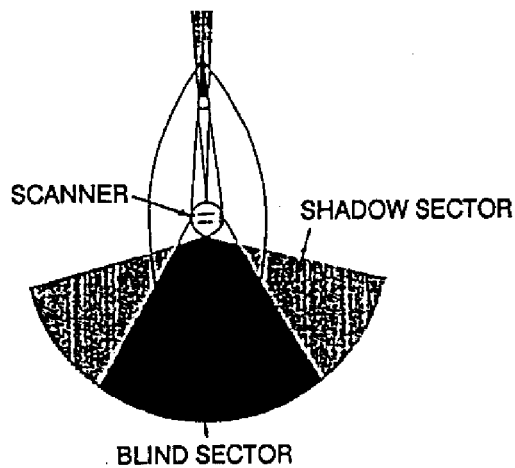

*Figure 5-16 Shadows caused  
by objects*

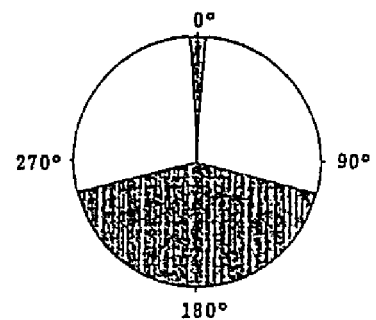

*Figure 5-17 Shadow sector  
diagram for scanner unit  
sited in Figure 5-17*

*This page intentionally left blank.*

## List Of Outline Drawings and Circuit Diagrams

Table D-1 Outline drawings

No.	Name	Type	Drawing No.	Page
1	Display Unit	RDP-104	C3379-G01	D-1
2	Radar Scanner Unit	XN8/12A-RSB-0061/62	C3380-G01	D-2

Table S-1 Circuit diagrams

No.	Name	Type	Drawing No.	Page
1	Interconnection Diagram	MODEL 1931/1941	C3380-C01	S-1
2	Display Unit	RDP-104	C3379-K02	S-2
3	Radar Scanner Unit	RSB-0061-039 RSB-0062-040	C3380-K01	S-3

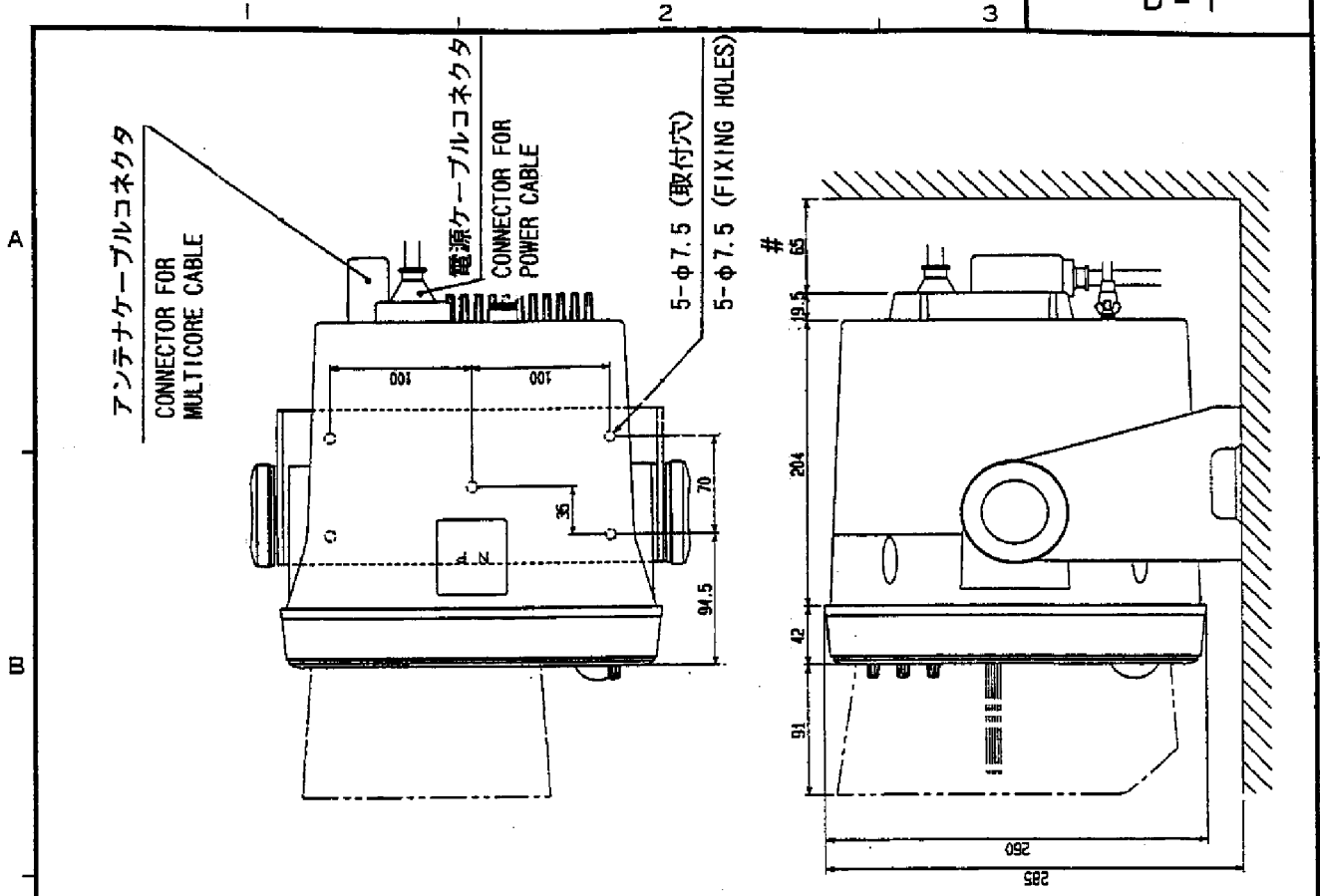

注記  
1) 各接続ケーブルはサービス時、指示部を前方に十分引き出せるよう余裕をもたせること。  
2) #印寸法は最小サービス空間とする。

NOTE  
1) LEAVE SUFFICIENT SLACK IN CABLES SO THAT THE UNIT CAN BE DRAWN OUT WITH THE CABLES CONNECTED FOR MAINTENANCE.  
2) # : RECOMMENDED SERVICING CLEARANCE.

コンパス安全距離  
COMPASS SAFE DISTANCE

スタンダード STANDARD	0.8 m
ステアリング STEERING	0.6 m

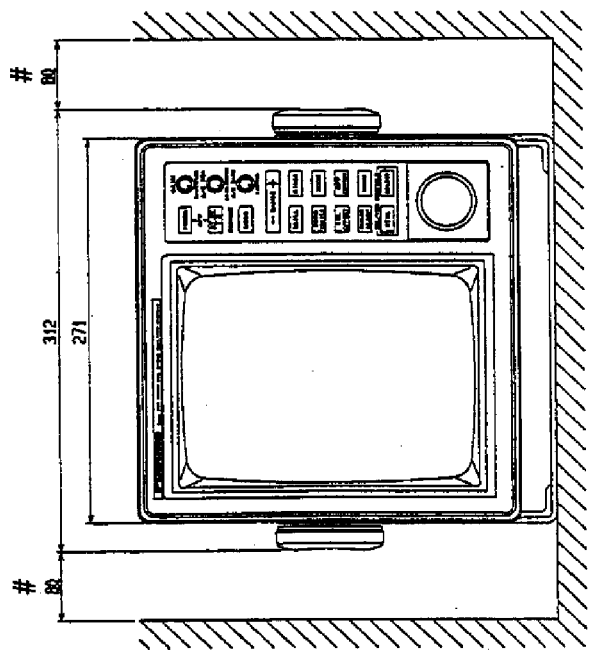

MODEL 1831/1931  
MODEL 1941/1941R

品番 ITEM	品名 NAME	材質 MATERIAL	数量 Q'TY	図番 DWG.NO.	備考 REMARKS
------------	------------	----------------	------------	---------------	---------------

承認 APPROVED	FEB. 25. '93 M. IKEDA	三角法 THIRD ANGLE PROJECTION		名称 TITLE	
検図 CHECKED	FEB. 23. '93 TAKAHASHI	尺度 SCALE	1/5	RDP-104 レーダー指示部外寸図 RDP-107 RADAR DISPLAY UNIT	
製図 DRAWN	FEB. 23. '93 N. SAITO	重量 WEIGHT	6.5 kg	図番 DWG.NO.	C3379-G01-C

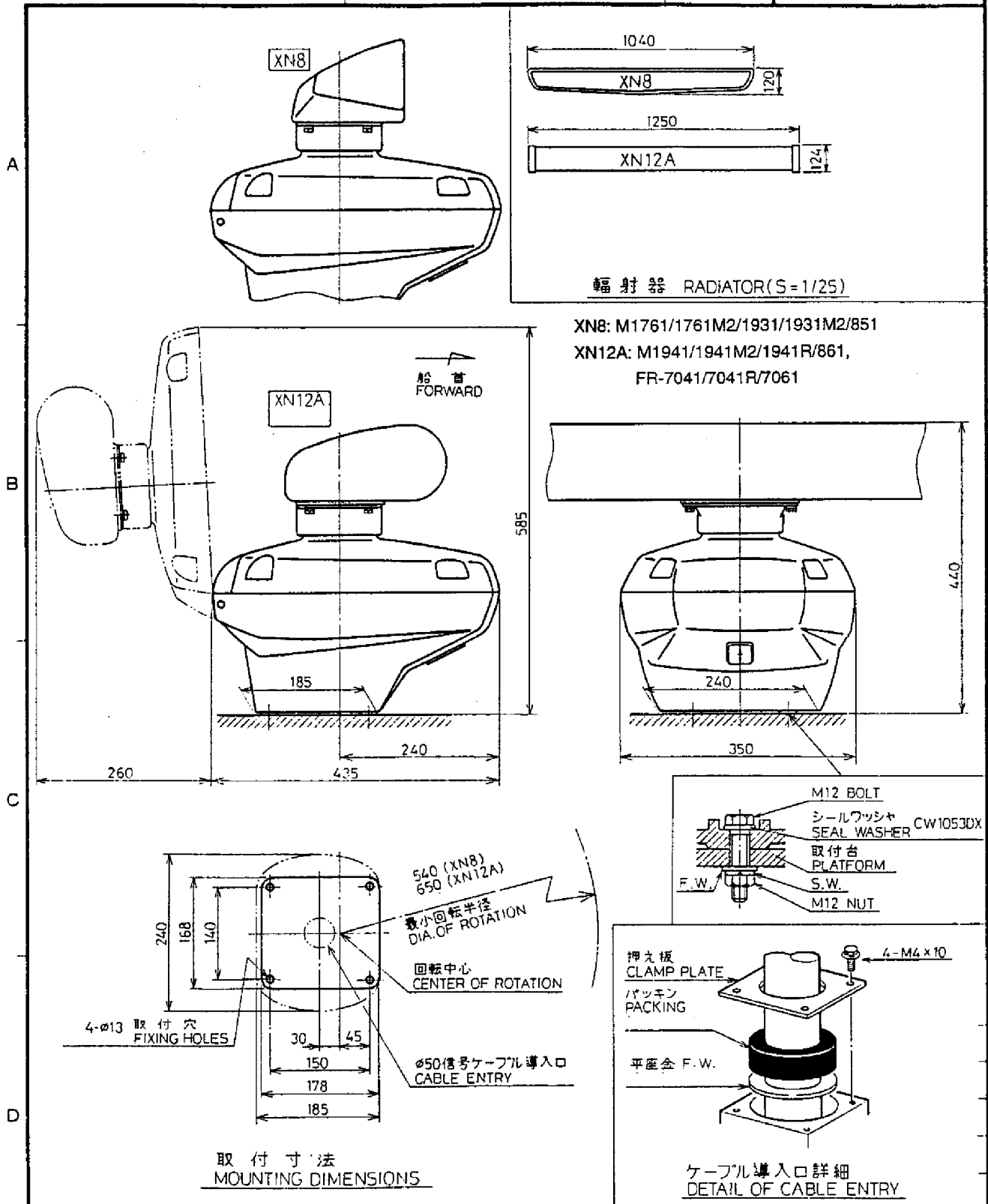

輻射器 RADIATOR(S=1/25)

XN8: M1761/1761M2/1931/1931M2/851  
 XN12A: M1941/1941M2/1941R/861,  
 FR-7041/7041R/7061

取付寸法  
 MOUNTING DIMENSIONS

ケーブル導入口詳細  
 DETAIL OF CABLE ENTRY

品番 ITEM	品名 NAME	材質 MATERIAL	数量 Q'TY	図番 DWG.NO.	摘要 REMARKS
承認 APPROVED	OCT-22-92 M. IKEDA	三角法 THIRD ANGLE PROJECTION	名称 TITLE	XN8-RSB-0061, XN12A-RSB-0062/65 レーダー空中線部 RADAR SCANNER UNIT	
検図 CHECKED	OCT-22-92 T. TAKAHASHI	尺度 SCALE	重量 WEIGHT	図番 DWG.NO.	
製図 DRAWN	OCT-22-92 I. AMANO	23(XN8) 20(XN12A) kg	C3380-G01-E		



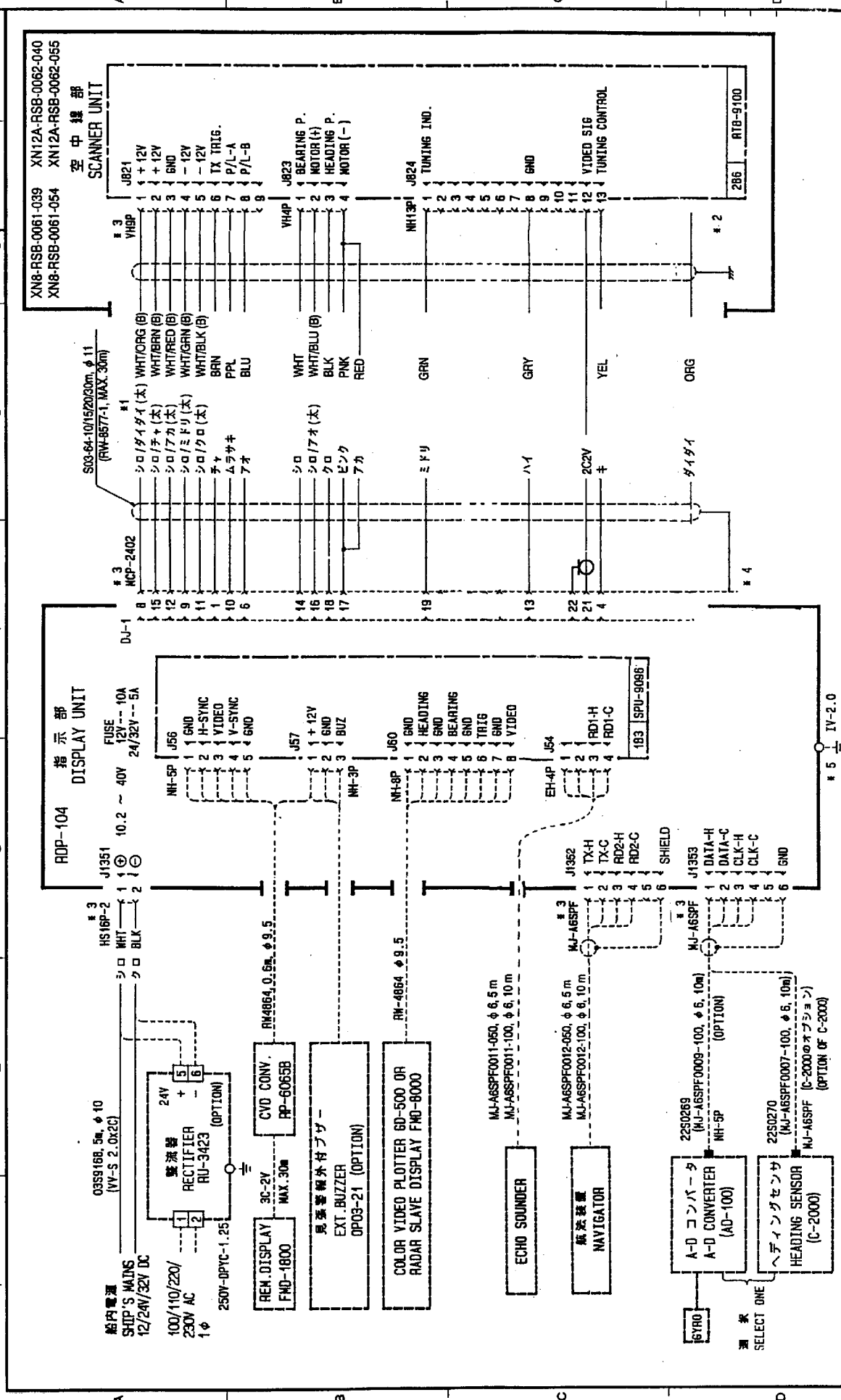

- \* 1. (木) : 本線
  - \* 2. 空中線部側のシールドは完全にアースすること。
  - \* 3. コネクターケーブル取付済。
  - \* 4. シールドはコネクターケースを通してアースされている。
  - \* 5. 造船所支給。
- \* 1. (B) : LARGE WIRES.
  - \* 2. SHIELD SHOULD BE EFFECTIVELY GROUNDED AT SCANNER UNIT.
  - \* 3. CONNECTOR PLUG FACTORY-WIRED.
  - \* 4. SHIELD GROUNDED THRU CONNECTOR CASE.
  - \* 5. SHIPYARD SUPPLY.

DRAWN	DATE	REVISED	TYPE
Y. S. K.	95.10.10		名称
APPROVED			相互接続図
SCALE			BLOCK NO.
DATE			FIG. NO.

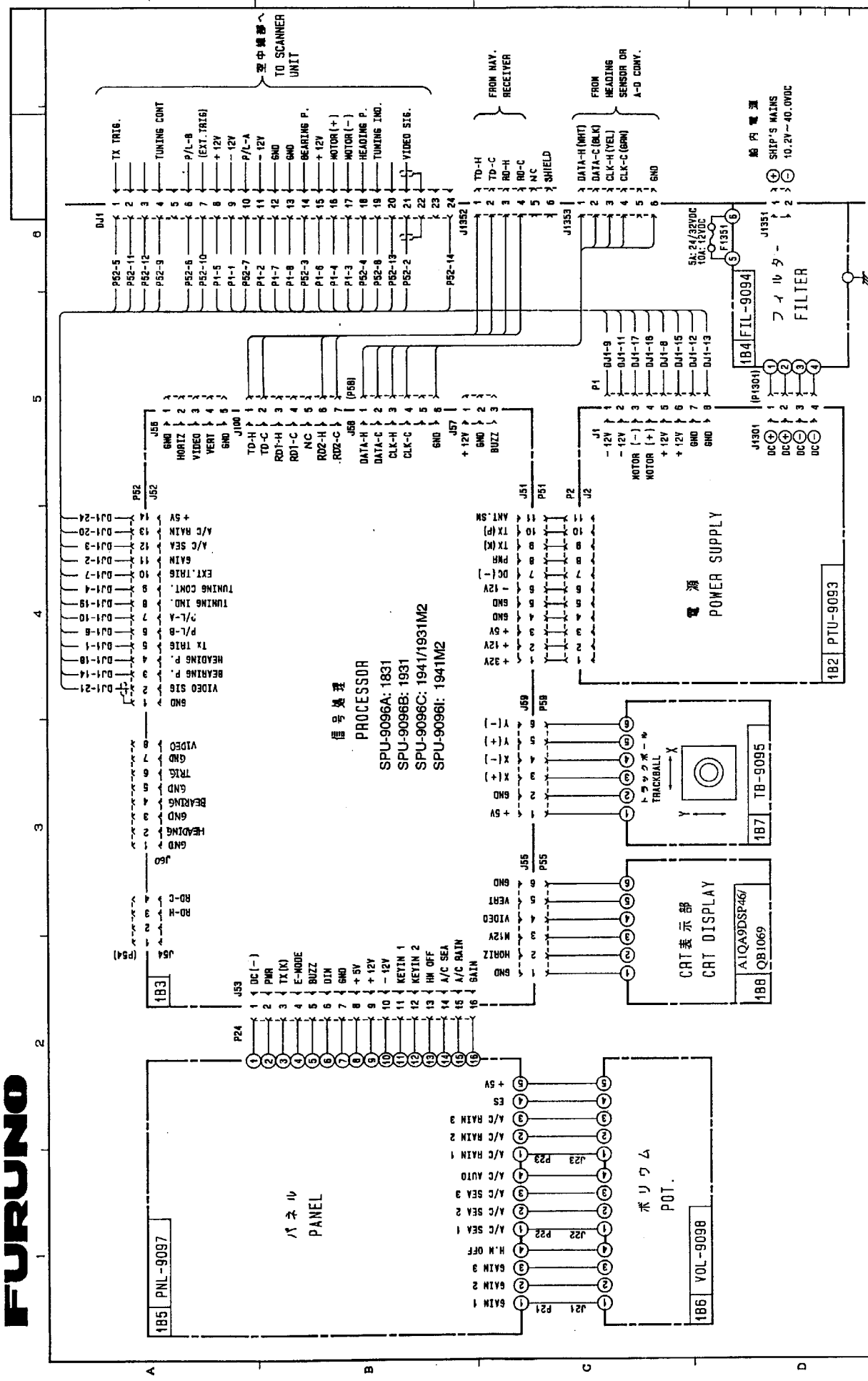

承認 APPROVED	ARR-21-'93 M. IKEDA	名称 TITLE	指示部 DISPLAY UNIT
検閲 CHECKED	ARR-21-'93 M. IKEDA	製造 DRAWN	DWG. NO. C3379-K02-G
製図 DRAWN	ARR-20-'93 Y. HATAI		

MODEL 1831 MARK-2  
 MODEL 1931 MARK-2  
 MODEL 1941 MARK-2

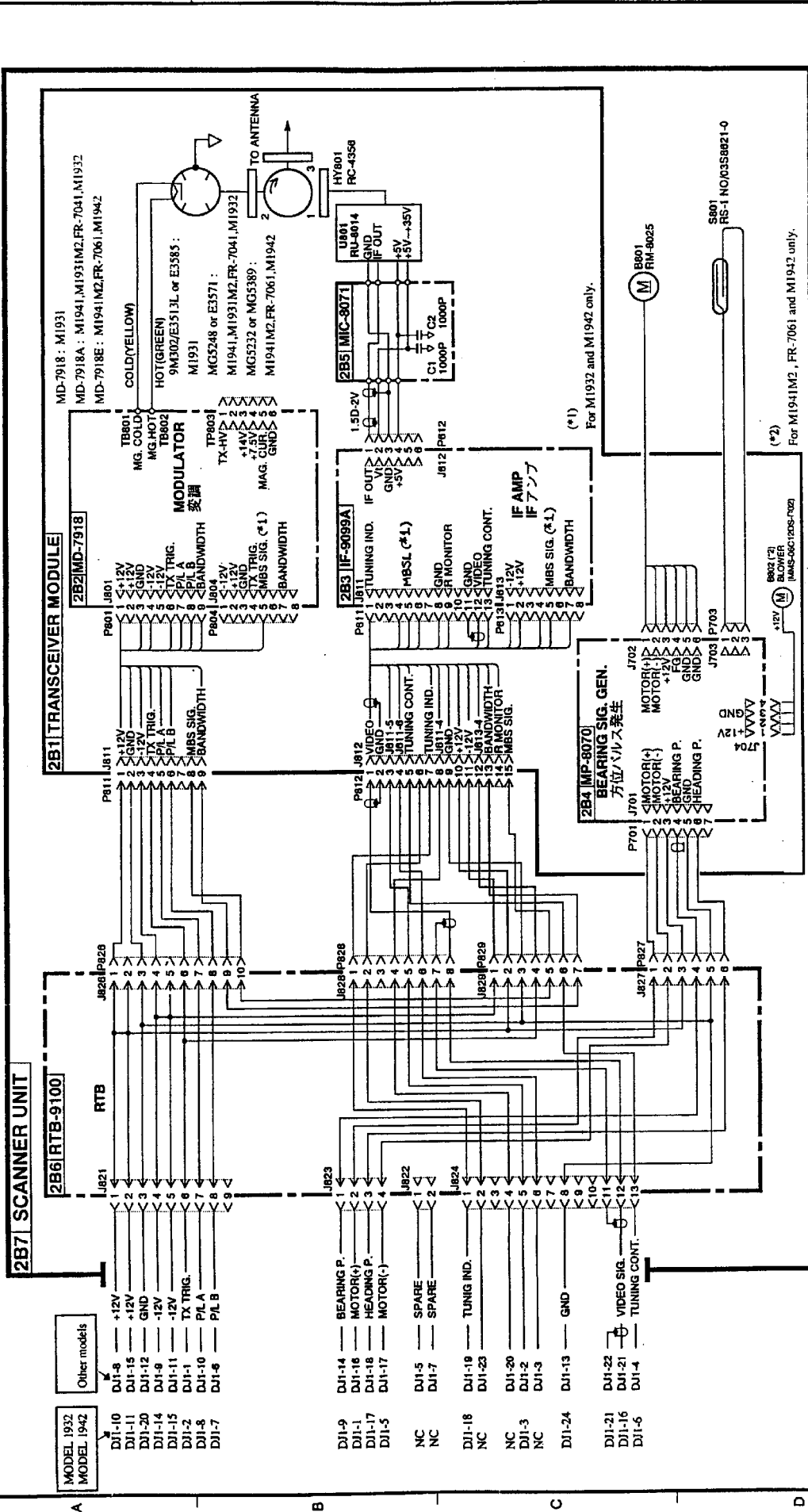

MD-7918 : M1931  
 MD-7918A : M1941, M1931M2, FR-7041, M1932  
 MD-7918E : M1941M2, FR-7061, M1942

COLD(YELLOW)  
 HOT(GREEN)  
 9M002/E313L or E3585 :  
 M1931  
 MC5248 or E3571 :  
 M1941, M1931M2, FR-7041, M1932  
 MC5532 or MC5389 :  
 M1941M2, FR-7061, M1942

(\*)  
 For M1932 and M1942 only.

(\*\*)  
 For M1941M2, FR-7061 and M1942 only.

品番 ITEM	品名 NAME	材質 MATERIAL	数量 QTY	図番 DWG. NO.	備考 REMARKS
承認 APPROVED	Dec 10 '96 F. K. S. I. N. A.	形式 THIRD ANGLE			
検図 CHECKED	Dec 10 '96 K. O. K. A. N. A. T. O.	尺度 SCALE			
製図 DRAWN	Dec 10 '96 K. O. K. A. N. A. T. O.	重量 WEIGHT			
FR-7061 FR-7041 MODEL 1942 MODEL 1932 MODEL 1941 MARK2 MODEL 1931 MARK2 MODEL 1941 MODEL 1931		RSB-0061 RSB-0062		空中線部 SCANNER UNIT	
		kg	DWG. NO	C3380 - K01 - K	